

# COUGAR

SKILL LEVEL 1 - Recommended for Beginning Rocketeers

RECOMMENDED ENGINES:

A8-3 (First Flight), B4-4, B6-4, B8-5, C6-5

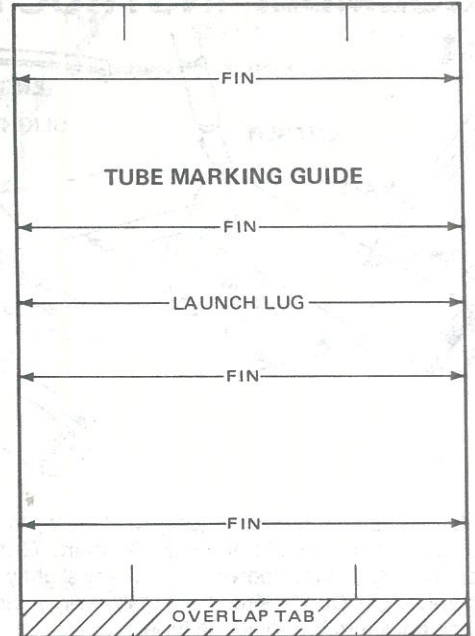
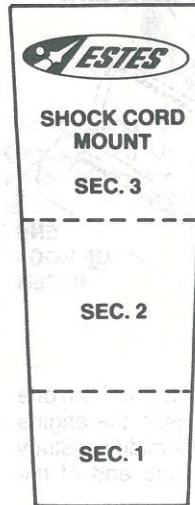
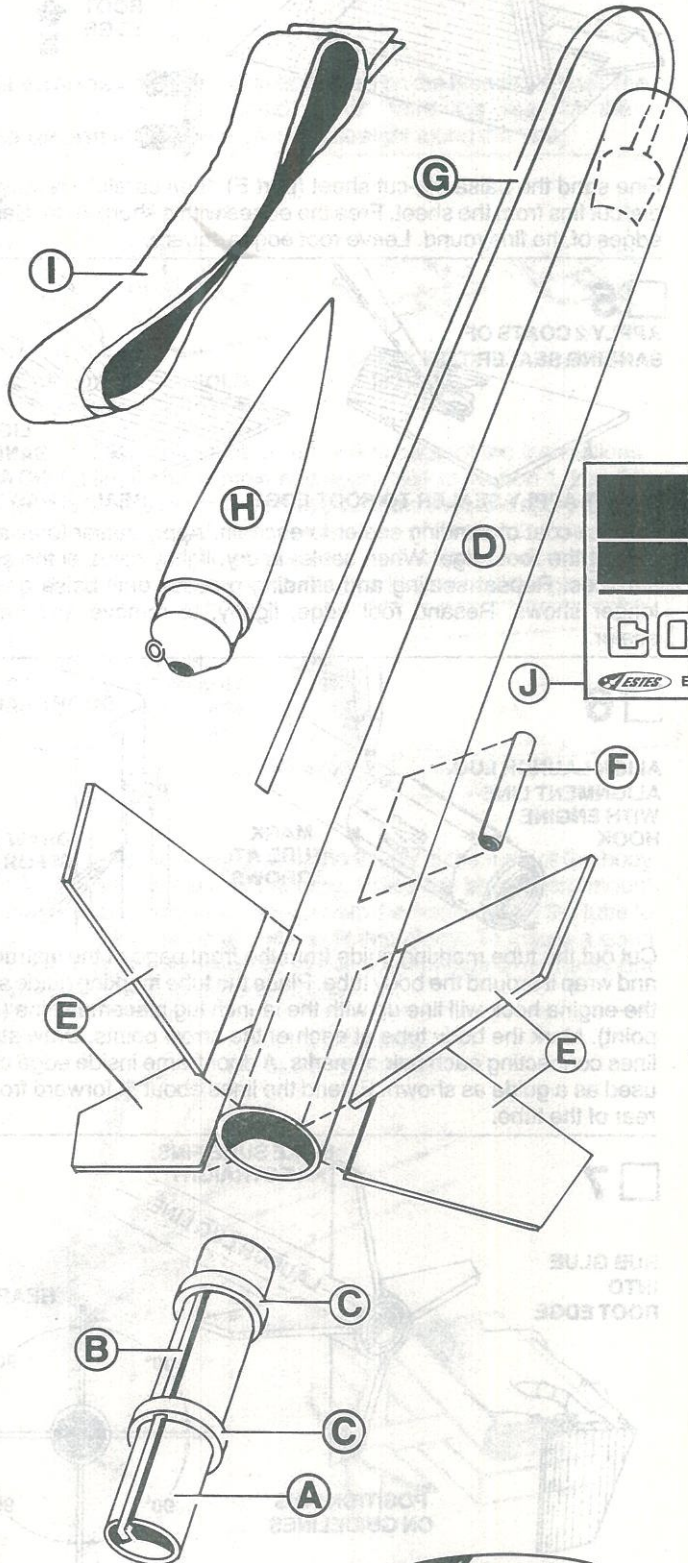

## BEFORE YOU START

Read each step and study the accompanying drawings before doing any of the work called for in that step. Make sure you have all parts and materials. Check off each step as you complete it. Always test-fit parts together before applying glue. It will sometimes be necessary to sand edges of rings, tubes, etc. to obtain proper fit. If you are in doubt about the relative size or location of some parts, refer back to this exploded view drawing for clarification. Adequate glue joints are very important for a flying model rocket. Follow the instructions carefully in this respect.

## TOOLS AND MATERIALS

In addition to the parts included in this kit you will need: Scissors, pencil, ruler, fine or extra-fine grit sandpaper, sanding sealer, a medium-size modeling paint brush, masking tape, modeling knife with sharp blade, gloss white and gloss blue enamel spray paints, and household white glue or resin glue (Elmer's, Titebond, or similar). Other types of glue are not recommended.

For easy and positive alignment of the fins on your model, we recommend the use of Estes' Fin Alignment Guide, Part No. 2231.

## PARTS LIST

## KIT #1923

A	1	Engine Mount Tube (type BT-20J)	30326
B	1	Engine Hook (type EH-2)	35025
C	2	Centering Ring (type AR-2050)	30164
D	1	Body Tube (type BT-50L)	30366
E	1	Die-Cut Balsa Sheet (type BF-1923)	32623
F	1	Launch Lug (type LL-2B)	38178
G	1	Shock Cord (type SC-1)	85730
H	1	Nose Cone (type PNC-50Y)	71009
I	1	Streamer (type RS-20)	38278
J	1	Decal Sheet (type KD-1923)	37238



# ASSEMBLY INSTRUCTIONS

1

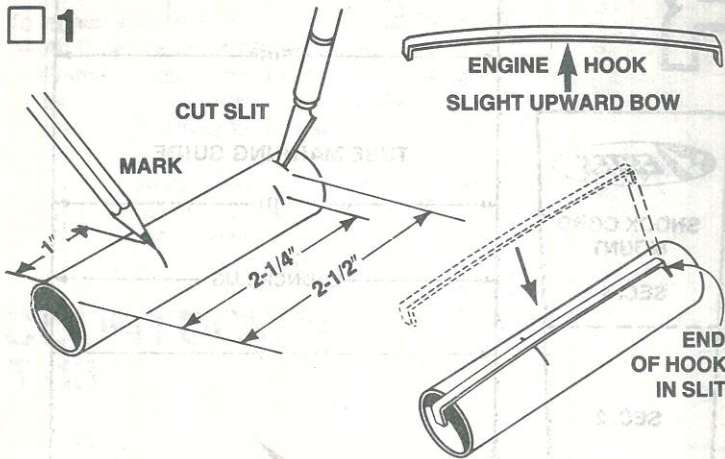

Mark the engine mount tube (part A) at 1", 2-1/4" and 2-1/2" from one end. Cut a 1/8" long slit at the 2-1/2" mark. Gently bend the engine hook (part B) so that it bows upward very slightly in the middle. (Study the drawing.—Don't bend the wrong way.) Insert one end of the engine hook into the slit in the tube.

2

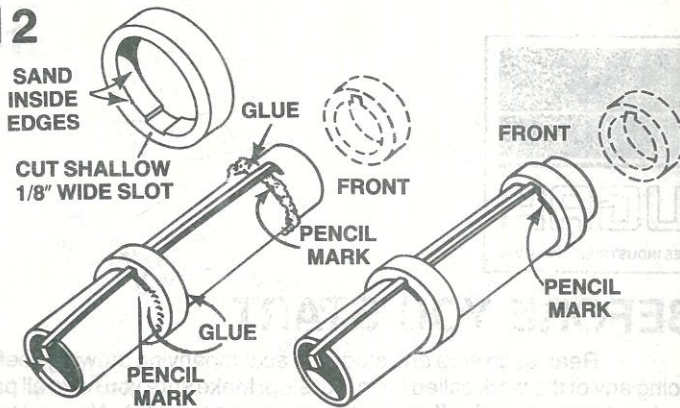

Sand the inside edges of the two centering rings (part C) to remove burrs. The rings should slide easily onto the engine mount tube. Cut a very shallow 1/8" wide slot inside the two centering rings so they will fit over the engine hook. Slip one ring onto the front end of the engine mount tube and slide it down to the 1" mark. Make sure the engine hook runs straight down the tube, then apply glue to both sides of this ring. Apply glue around the tube at the 2-1/4" mark and slide the remaining centering ring into place down to the 2-1/4" mark.

3

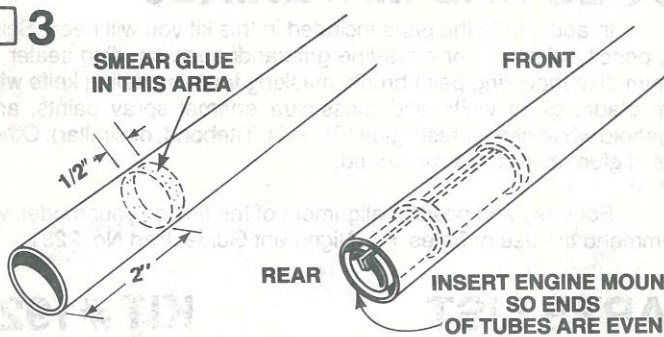

The engine mount unit will be pushed into place so that the rear of the engine mount unit (end with engine hook projecting) is even with the rear of the body tube. Test-fit the engine mount unit several times by smoothly inserting and removing it. Sand if necessary to assure a smooth fit. Once this can be smoothly and easily done, remove the engine mount unit. Apply a ring of glue around the inside of the rear of the main body tube (part D) about 2" to 2-1/2" from the end of the tube. Make certain that the engine hook is to the rear and insert the engine mount unit with one smooth motion. Do not pause, or the glue may "lock" with the engine mount unit in the wrong position.

4

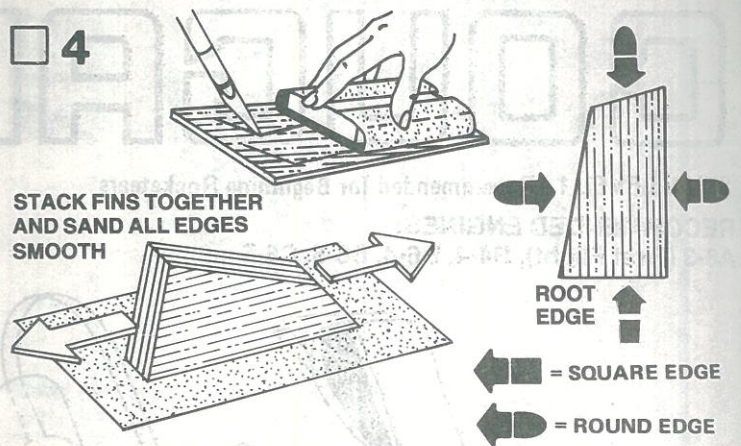

Fine sand the balsa die-cut sheet (part E), then carefully remove the die-cut fins from the sheet. Free the edges with a sharp knife. Sand all edges of the fins round. Leave root edges square.

5

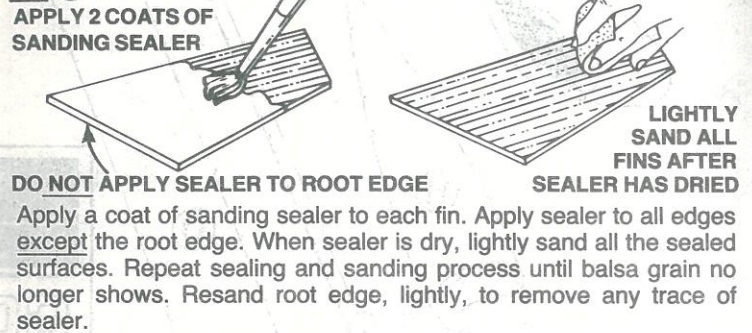

6



Cut out the tube marking guide from the front page of the instructions and wrap it around the body tube. Place the tube marking guide so that the engine hook will line up with the launch lug placement line (arrow point). Mark the body tube at each of the arrow points. Draw straight lines connecting each pair of marks. A door frame inside edge can be used as a guide as shown. Extend the lines about 6" forward from the rear of the tube.

7

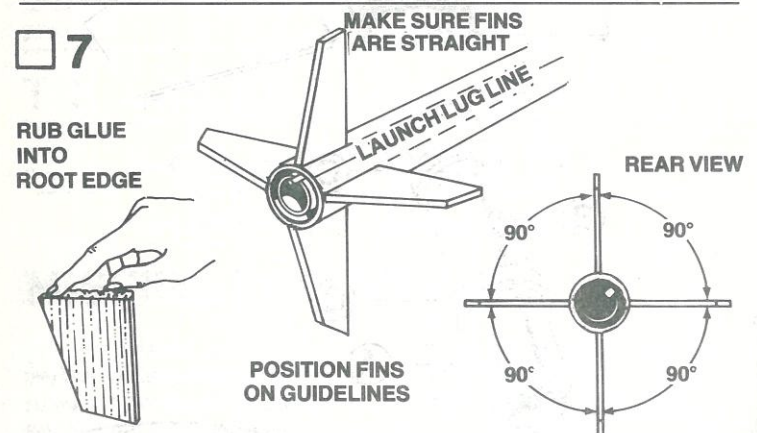

Rub glue into the root edge of each fin and allow to dry. Apply glue to the fins again and position fins on the alignment lines in positions shown. Adjust the fins so they project straight away from the body tube. DO NOT set the rocket on its fins while the glue is wet.

8

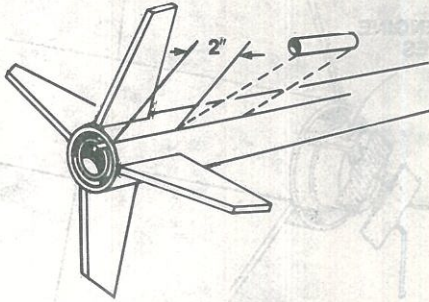

Glue launch lug (part F) to rocket body tube on the launch lug line. The rear of the launch lug should be 2" from the rear of the rocket body tube. Align the launch lug straight along the body.

9

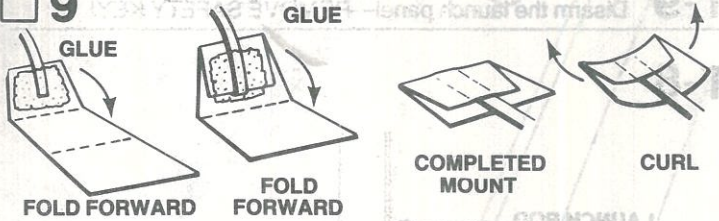

Cut out the shock cord mount from the first page of the instructions. Fold on dotted lines, then unfold and apply glue to section 1. Lay the end of the shock cord (part G) into the glue. Fold over and apply glue to the back of Section 1 and the exposed portion of Section 2. Fold again to complete mount. Curl the edges of the mount up so it will match the contour of the body tube and hold with your fingers until the glue sets.

10

**SMEAR A FILM OF GLUE OVER MOUNT AND SURROUNDING AREA**

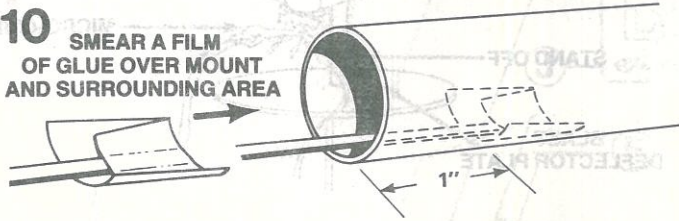

Use a finger or stick to apply glue to the inside of the front of the body tube 1" to 2" from the front of the tube. Press the shock cord mount firmly into position in glue far enough from the front edge of the tube to allow clearance for the nose cone to fit into place. To insure a good bond use a stick or your finger to smear a film of glue over the mount and surrounding area in the body tube.

11

**APPLY THIN LINE OF GLUE TO JOINTS**

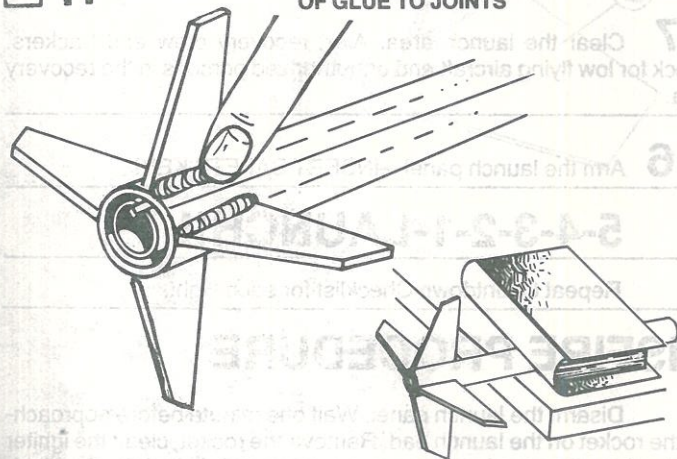

When the glue on the fin joints has dried, apply a glue reinforcement to each fin/body tube joint. Holding the model level, apply a line of glue to both sides of each fin joint and on both sides of the launch lug. Smooth out the glue with your finger. **IMPORTANT**—Support rocket on table edge as shown until the glue dries.

12

**CLEAR EYELET**

**TRIM EXCESS PLASTIC**

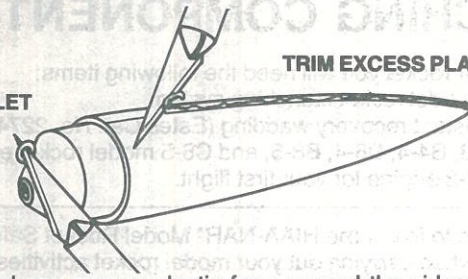

Trim or sand any excess plastic from around the sides of the nose cone (part H). Use a sharp knife to remove any excess plastic from the inside of the molded eyelet at the rear of the nose cone. Wash the nose cone with lukewarm soapy water, rinse well, and dry.

13

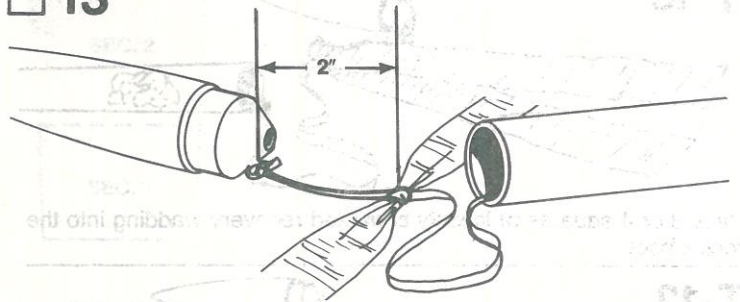

Using a double knot, tie the shock cord around the middle of the plastic streamer (part I) about 2" from the end of the shock cord. Attach the free end of the shock cord to the nose cone with a firm knot.

## PAINTING AND DETAILING

14

**PAINT THE ENTIRE MODEL GLOSS WHITE**

**NOTE: APPLY FINAL COAT WITH "WET" LOOK**

**USE ROLLED PAPER FOR ROCKET HOLDER**

**MASKING TAPE AND PAPER PROTECT MODEL FROM SECOND COLOR SPRAY**

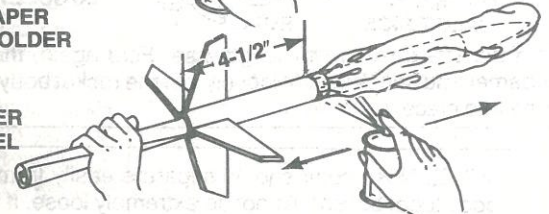

After the sanding sealer and glue are completely dry, paint the entire model gloss white. Follow instructions on spray can for best results. We recommend spray enamel. Do not paint the model with lacquer paint. Shake can before spraying. Hold can straight up and spray in long, smooth "strokes". Spray the model with several light, dry mist coats of paint to avoid "runs". Shake can periodically. Let the paint dry overnight. Apply masking tape and paper 4-1/2" from the rear of the rocket to cover and protect the areas which will remain white. Paint the fins and the rear of the body tube gloss blue. Carefully remove the masking tape and paper as soon as the paint is dry.

## DECAL PLACEMENT

15

**START DECAL AT THE FRONT OF LAUNCH LUG**

**SLIP BACKING PAPER OUT FROM UNDER DECAL**

**POSITION COUGAR NAME DECAL IN FRONT OF STRIPES AND SLIP BACKING PAPER OUT FROM UNDER DECAL**

Apply the decal (part J) in the position shown. Cut out decal, dip in lukewarm water for 10-20 seconds, and hold it until it starts to uncurl. Slip decal onto front portion of rocket body tube and rotate rocket while slipping backing paper out from under decal. Match up ends of decal and blot away excess water. For best results, let the model dry overnight and apply a coat of clear spray to protect the decal.

# LAUNCHING COMPONENTS

To launch your rocket you will need the following items:

- An Estes model rocket launching system
  - Flame resistant recovery wadding (Estes Cat. No. 2274)
  - Estes A8-3, B4-4, B6-4, B8-5, and C6-5 model rocket engines.
- Use an A8-3 engine for your first flight.

Be sure to follow the HIAA-NAR\* Model Rocket Safety Code when carrying out your model rocket activities.

- \*HIAA—Hobby Industry of America
- \*NAR—National Association of Rocketry

## COUNTDOWN CHECKLIST

### T-13

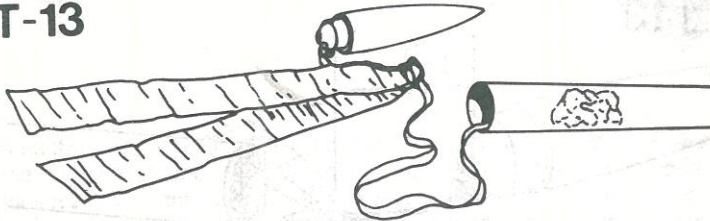

Pack 3 or 4 squares of loosely crumpled recovery wadding into the rocket body.

### T-12

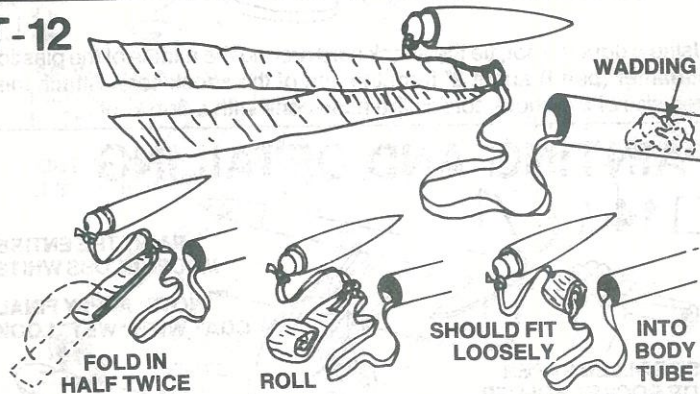

Fold the streamer in half lengthwise. Fold again, then roll until the streamer and shock cord fit loosely into the rocket body. Slide the nose cone into place.

**NOTE:** Nose cone should separate easily from rocket body tube, but should not be extremely loose. If fit is too tight, sand inside of body tube and shoulder of nose cone with fine sandpaper. If fit is too loose, add a wrapping of transparent tape to the shoulder of the nose cone.

### T-11

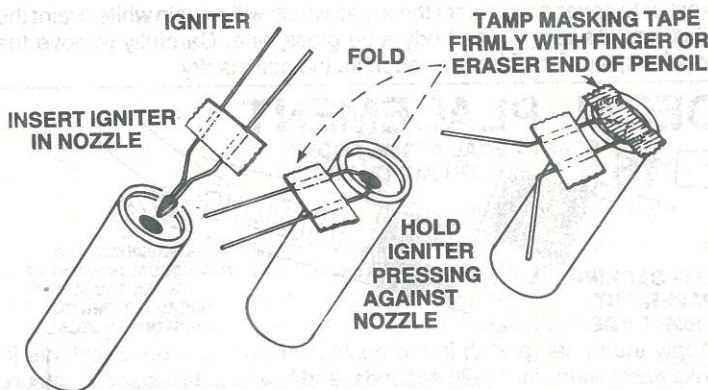

Select an engine and install an igniter as directed in the engine instructions. Use an A8-3 engine for your first flight.

### T-10

**MAKE SURE ENGINE HOOK LATCHES SECURELY**

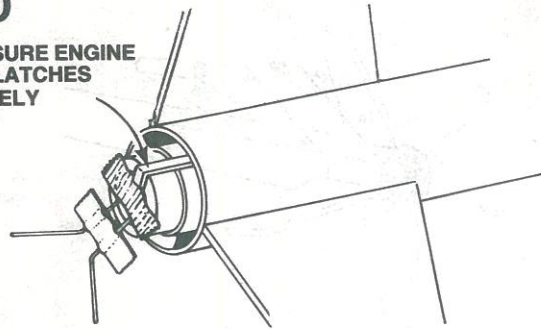

Insert engine into rocket engine mount. Engine hook must latch securely over end of the engine.

### T-9

Disarm the launch panel—REMOVE SAFETY KEY!

### T-8

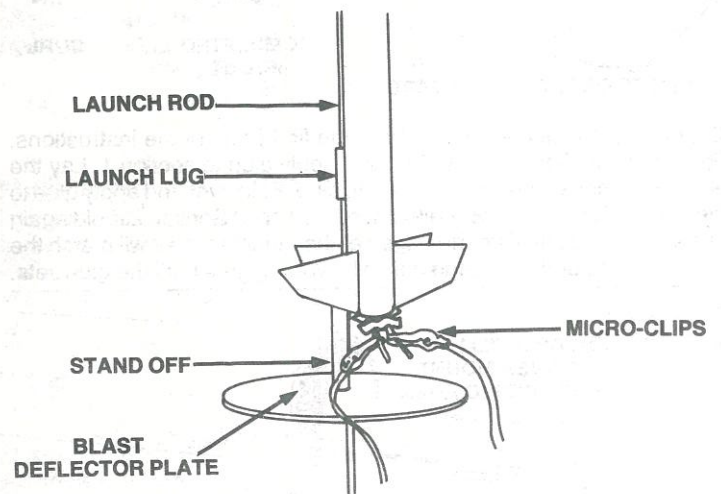

Slide the launch rod through rocket launch lug and place rocket on launch pad. Make sure the rocket slides freely on the launch rod. Clean the micro-clips and attach them to the igniter wires. Arrange the clips so they do not touch each other or the metal blast deflector. Attach clips as close to protective tape on igniter as possible.

### T-7

Clear the launch area. Alert recovery crew and trackers. Check for low flying aircraft and unauthorized persons in the recovery area.

### T-6

Arm the launch panel—INSERT SAFETY KEY!

## 5-4-3-2-1-LAUNCH!!

Repeat Countdown Checklist for each flight.

## MISFIRE PROCEDURE

Disarm the launch panel. Wait one minute before approaching the rocket on the launch pad. Remove the rocket, clean the igniter residue from the nozzle of the engine, and carefully install a new igniter. Repeat the Countdown Checklist.

Failure of the rocket engine to function properly is nearly always caused by a failure to install the igniter correctly. This failure permits the igniter to heat and burn into two pieces without igniting the engine.