



ESTES INDUSTRIES  
1295 H STREET  
Penrose, CO 81240  
The World Leader in  
Model Rocketry

# ASTROCAM<sup>®</sup>

(8-97) 8411.  
EST 1813

## READY-BUILT™ FLYING MODEL ROCKET INSTRUCTIONS

### 1. PARACHUTE ATTACHMENT

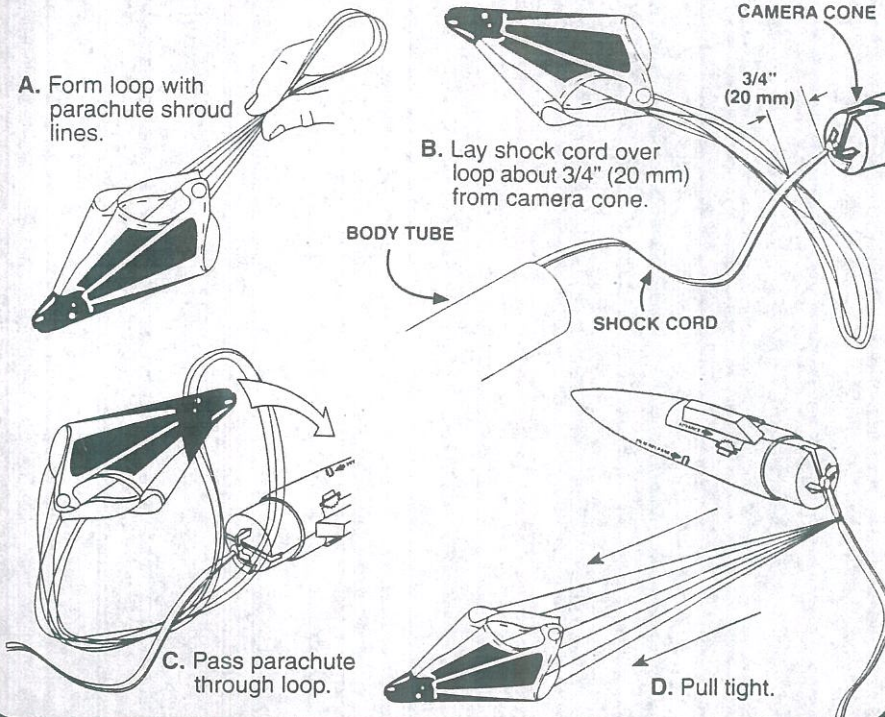

### 2. PREPARING THE PARACHUTE

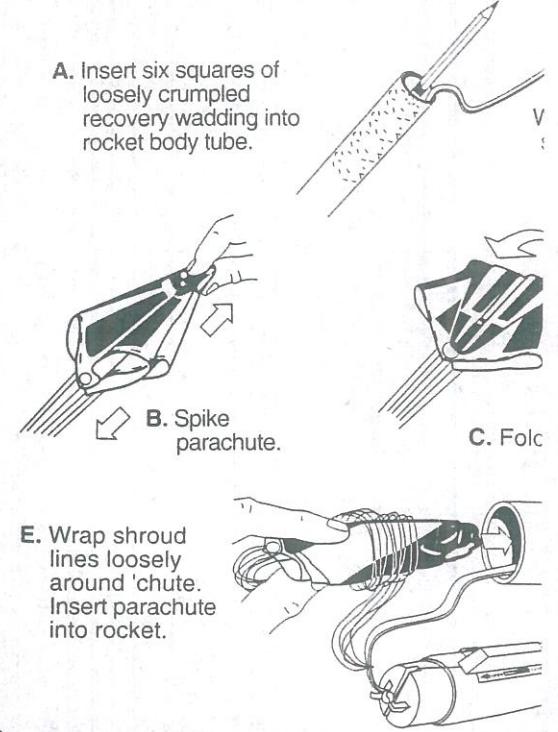

### 4. CAMERA OPERATION

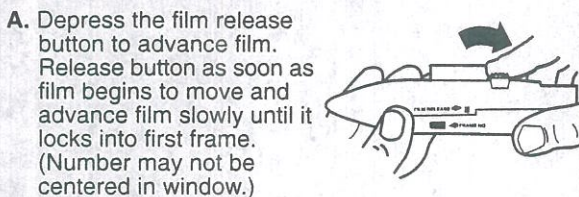

**NOTE:** Do not attempt to overwind or wind too fast as this may damage the camera.

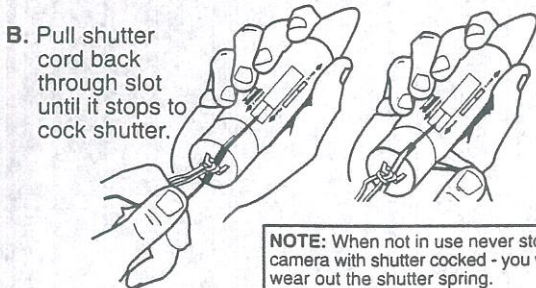

**NOTE:** When not in use never store camera with shutter cocked - you will wear out the shutter spring.

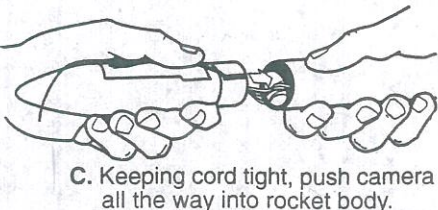

### 5. PREPARING THE ENGINE FOR FLIGHT

**WARNING: FLAMMABLE**  
Before proceeding read the NAR Safety Code and instructions included with engines. Prepare your engine **ONLY** when you are at the launch site preparing to launch! If you do not use your prepared engine, remove the igniter before storing your engine.

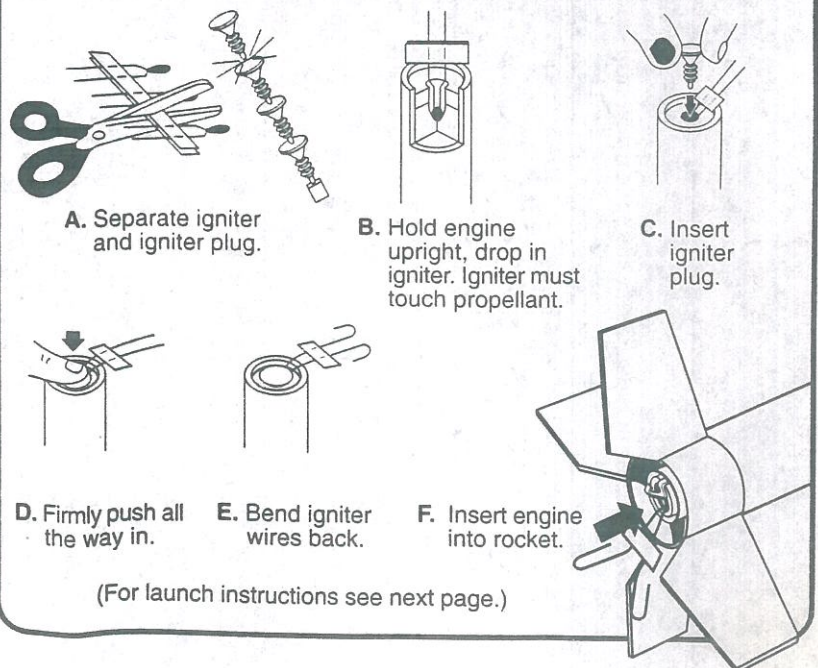



### 3. FILM INSTALLATION

A. Insert a small coin into opening at rear of film door and press back to open door.

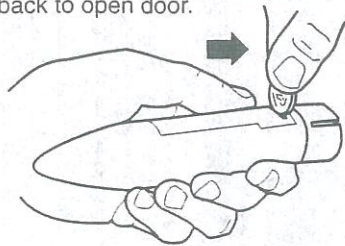

B. Insert film. Use ASA 200 color print 110 film cartridge **ONLY!** 12 exposure film is preferred.

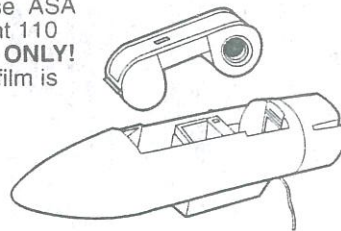

C. Rock advance wheel slightly to seat film all the way into camera.

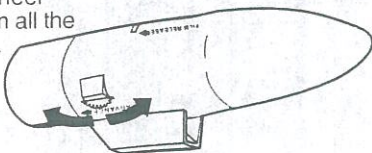

D. Insert front tab of film door under camera cone edge.

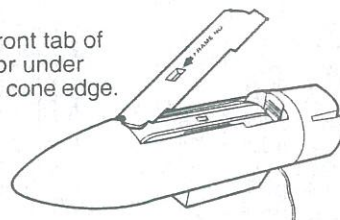

E. Press film door on with fingers.

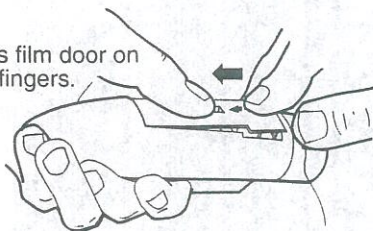

F. Push safety lock forward to closed position to keep from exposing film.

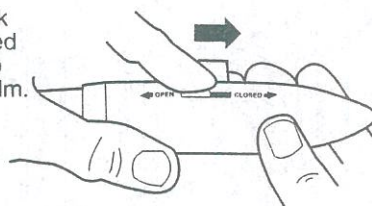

**NOTE:** A piece of tape can be placed over the back door to secure it to the main body of the AstroCam® RTF. This can prevent the film door from dislodging in the event of an impact during recovery.

**NOTE:** You will need to push safety lock to "open" before launching so a picture can be taken.

### TE FOR FLIGHT

#### IMPORTANT:

ing must be in place and easily for rocket to work properly!



D. Roll.

Parachute should slide easily into body tube. If fit is too tight, unfold and repack again.

### 5. AFTER LAUNCH

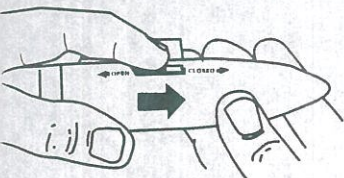

Push camera safety lock to "closed" position immediately upon recovery to protect the picture just taken from further exposure.

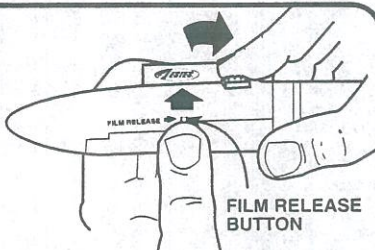

B. Depress the film release button to advance film. Release the button as soon as the film begins to move. Advance film slowly until it locks into next frame.

**NOTE:** Be sure to advance film immediately after taking a picture to avoid a double exposure.

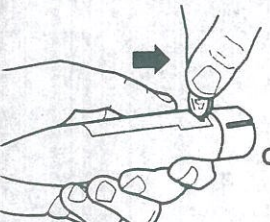

C. After the last picture has been taken, depress the film release button and advance the film until it stops at the end of the roll. Insert a small coin in the opening at the end of the film door and press back until the door catch releases. Holding the AstroCam® RTF with the film cartridge down, tap camera in the palm of your hand to remove the film.

**NOTE:** If you choose not to take all pictures on the roll, depress the film release and hold while advancing the film to the end.

### 7. FILM DEVELOPING

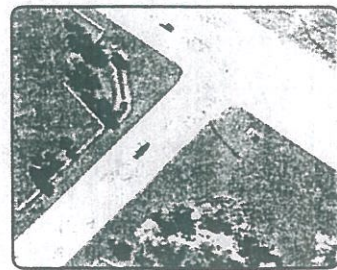
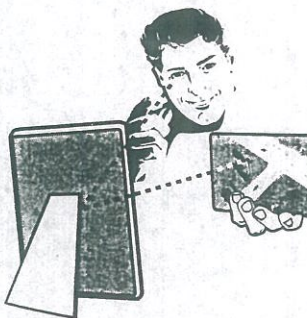

To view your AstroCam® RTF photo, stand in front of a mirror and hold a picture chin high. The picture reflected in mirror will be correct. AstroCam® RTF pictures not viewed in this fashion are reversed. Enlargements from AstroCam® RTF negatives are recommended not to exceed 5" x 7" (13 cm x 18 cm) size unless the quality and sharpness of the negative is exceptional. Your local photo shop can provide the best assistance.

The photo shown above is typical of the quality to be expected from the AstroCam® RTF camera. It was taken in a residential section of Eunice, LA. The photo was taken during mid-afternoon using a stock AstroCam®. When flying your AstroCam® RTF in residential areas, always use a large vacant lot or field as a launch site. In some instances a thin hazy crescent at the edge of a photo is a partial image of the nose portion of the camera.



## 8. CAMERA MAINTENANCE

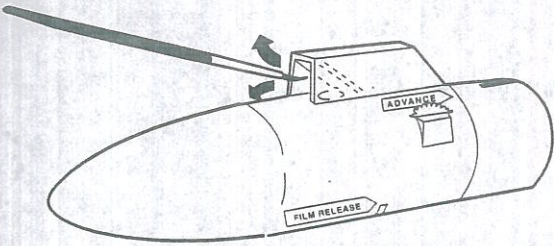

It is not recommended that the AstroCam® RTF be flown in areas with loose and dry soil, yet the camera may land on this type of terrain. When this happens, dust may collect on the mirror and lens and must be carefully removed before the camera is flown again. To do this, use a new, clean, small camel hair brush. Never use a brush that has been used for any other purpose, as any contaminants left in the bristles may mar the mirror and lens. Insert the tip of the brush into the mirror and lens cavity and stroke outward several times with very light pressure. Never insert any object into this cavity other than the brush for any purpose. Examine the mirror and lens carefully when cleaning to be sure all contaminants are removed. Clean the remainder of the camera's exterior with a soft cloth. AstroCam® RTF replacement parts can be ordered from Estes.

## 9. ABOUT FILM, FLIGHT AND FINISHED PHOTOS FROM YOUR ASTROCAM® RTF

Flying the AstroCam® RTF is fun and the photographic results exciting. The subjects which can be photographed are endless - city streets, schools, rural farmlands, etc. To achieve good pictures flight after flight, follow these simple guidelines.

- Be patient! Wait for a calm, clear day and use only the recommended ASA 200 color film or equivalent.
- For greatest ground detail, launch from 9 a.m. to 11 a.m. in the morning or 1 p.m. to 3 p.m. in the afternoon. Flying earlier or later than this will affect the light level being reflected from the ground. This may cause some under exposure. Also, long shadows on the ground may hide some detail in the finished photograph.
- Late spring, summer and early fall are the best times during the year to fly the AstroCam® RTF because of higher sun angles. Again, light reflected from the ground plays an important part in photo quality.
- Always prep the AstroCam® RTF carefully for each flight. Remember, you cannot expose the film as long as the safety lock is in the closed position. If you are unsure about shutter setting, release it and set it again. If you are unsure about whether the number appearing in the window has been exposed, advance to the next frame.
- The **only** recommended engine for the AstroCam® RTF is the C6-7. The AstroCam® RTF has been designed so that the engine type used will regulate the angle of the camera at the time of exposure.
- For best photo results and maximum altitude, launch on calm or nearly calm days with LAUNCH ROD IN VERTICAL POSITION.
- Never move the safety lock to the open position until the rocket is on the launch pad and you are actually ready to launch.
- Always move the safety lock to its closed position and advance film immediately upon recovery.

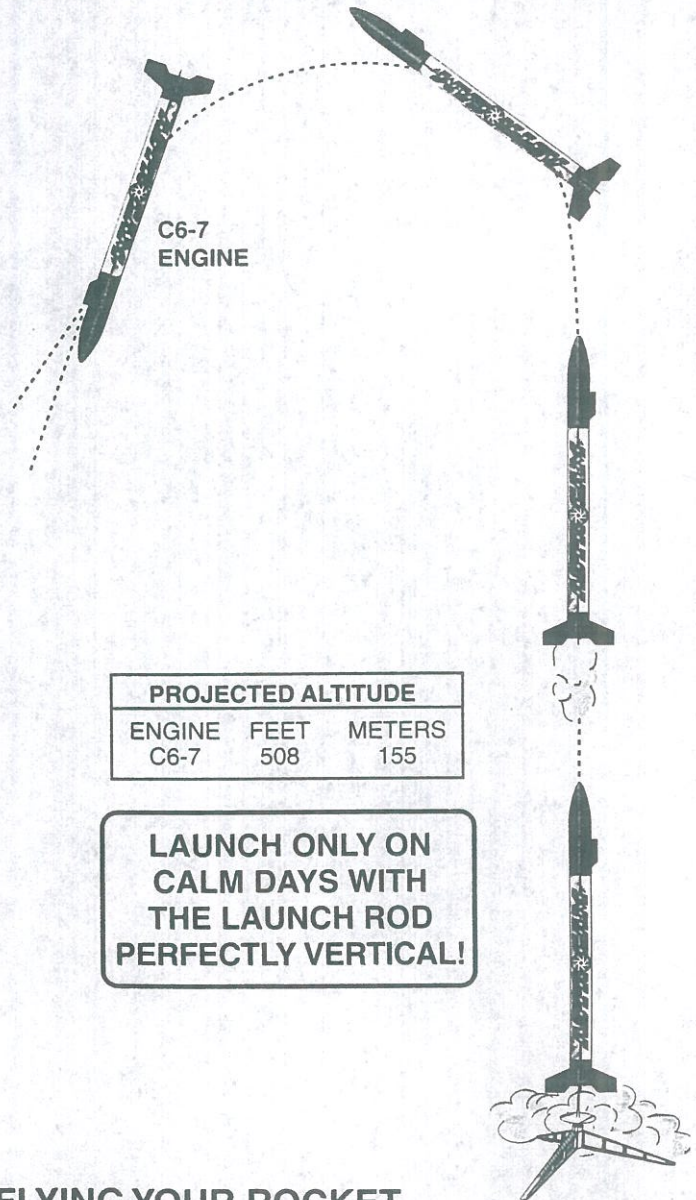

### LAUNCH SUPPLIES

To launch your rocket, you will need the following:

- Launch Pad (Estes Porta-Pad® II)
- Launch Controller (Estes Electron Beam®)
- Recommended Estes Engine: C6-7 only
- Recovery Wadding (EST 302274)
- Igniters and Igniter Plugs (included with Estes engines)

Use only Estes products to launch this rocket.

### TIPS FOR FLYING YOUR ROCKET

- Choose a large field away from power lines, tall trees, buildings, and low flying aircraft. Try to find a field at least 250 feet (76 meters) square. The larger the launch area, the better your chance of recovering your rocket.
- Launch area must be free of dry weeds and brown grass.
- Launch only during calm weather with little or no wind and good visibility.
- Don't leave parachute packed more than a minute or so before launch during cold weather (colder than 40° Fahrenheit [4° Celsius]).
- Always follow the National Association of Rocketry (NAR) MODEL ROCKETRY SAFETY CODE while participating in any model rocketry activities. The safety code is enclosed with this kit.



# COUNTDOWN AND LAUNCH

**10...** Safety key must not be in launch controller. The safety cap with safety key attached should already be on the launch rod.

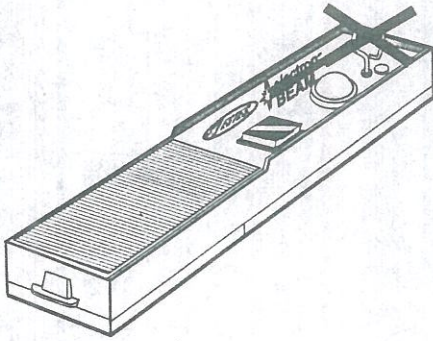

**9...** Remove safety cap from launch rod, slide launch lugs over rod. Make sure rocket slides freely and micro-clips are clean for good electrical contact.

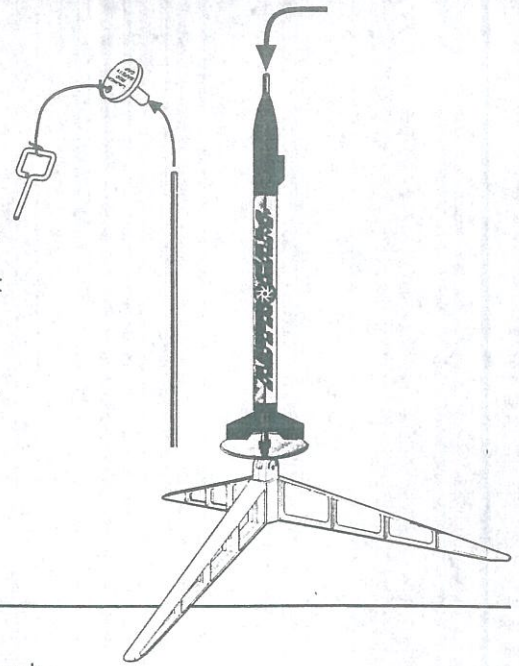

**8...** Attach micro-clips to the igniter wires. Arrange the micro-clips so they do not touch each other or the metal blast deflector. Attach microclips as close to protective tape on igniter as possible.

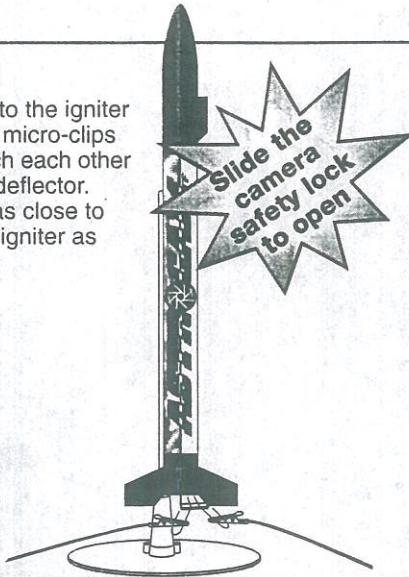

**7...** Move everyone back from your rocket as far as launch wire will permit (at least 15 feet [5 meters]).

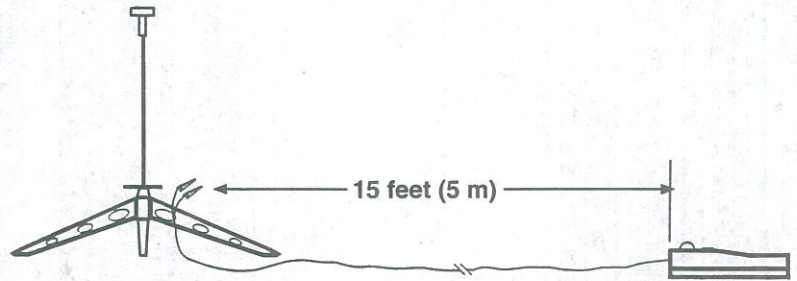

**6...** Insert safety key to arm the launch controller.

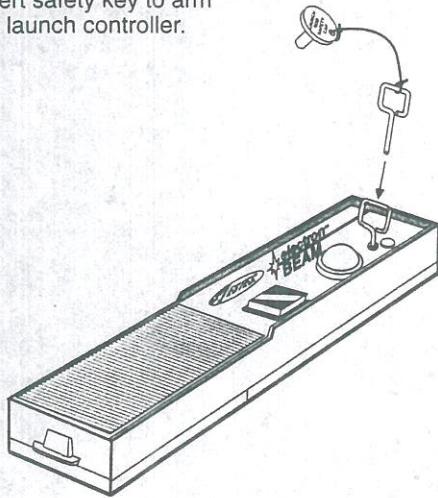

**5...** Start audible countdown.

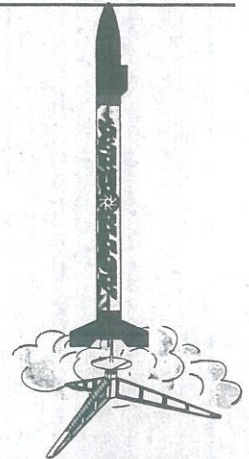

## LAUNCH!

Push and hold button until engine ignites.

**For safety, immediately remove safety key from launch controller and replace safety cap on launch rod.**

### MISFIRES

When an ignition failure occurs, **remove the safety key from the launch control system and wait one minute before approaching the rocket.** Remove the expended igniter from the engine and install a new one. Be certain the coated tip is in direct contact with the engine propellant. Broken or chipped coating will not affect the performance of the igniter. Reinstall the igniter plug as illustrated previously. Repeat the countdown and launch procedure.