

# NOMAD

## SURFACE TO SURFACE MISSILE

SKILL LEVEL 2 – Recommended for Intermediate Rocketeers.

### BEFORE YOU START

Read all instructions before beginning work on your model. Make sure you have all parts and materials. When you are thoroughly familiar with the assembly procedure, begin construction. Check off each step as you complete it. In each step, test-fit the parts together before applying any glue. If some part doesn't fit properly, sand lightly or build-up as needed for precision assembly.

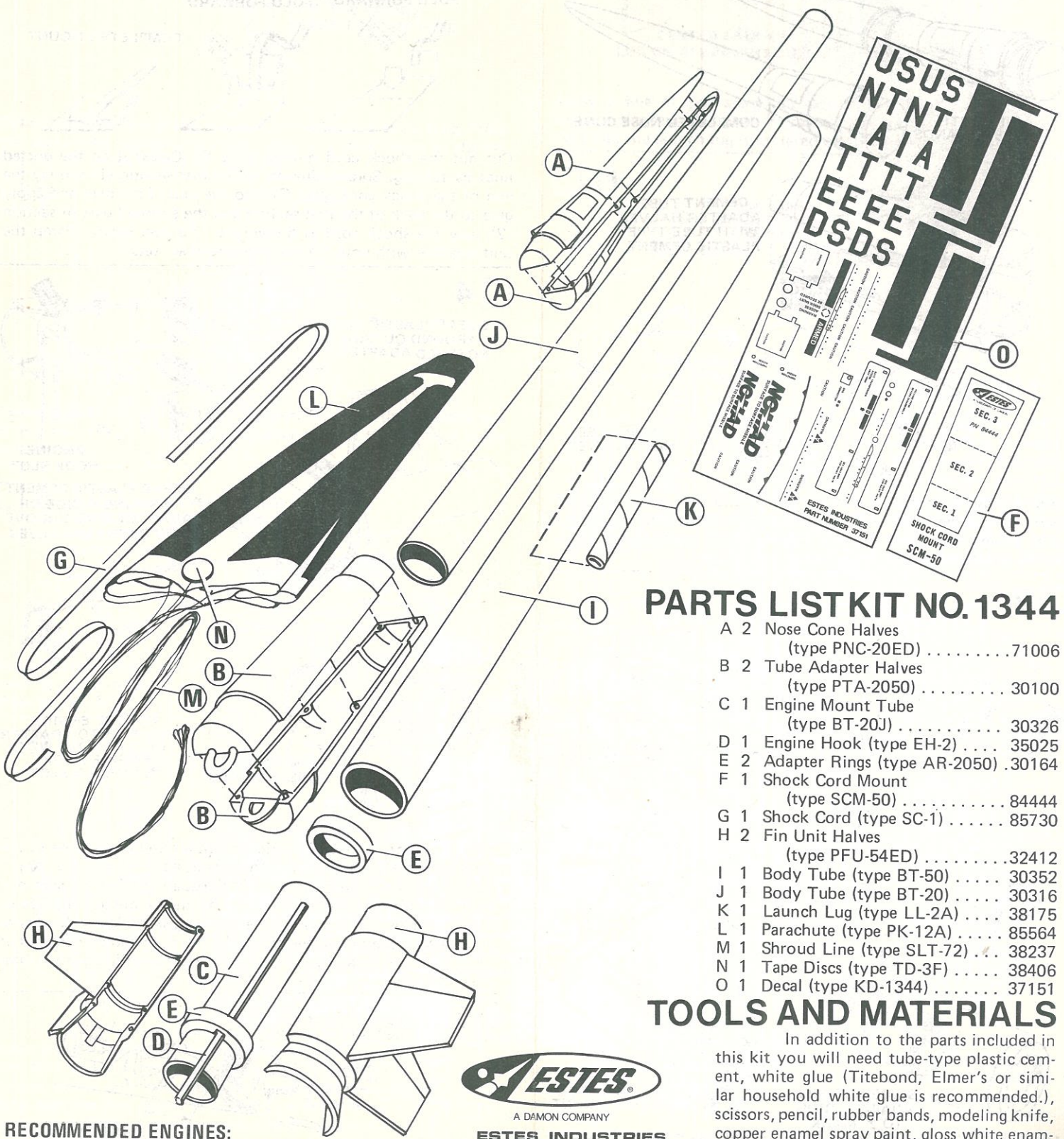

### PARTS LIST KIT NO. 1344

- A 2 Nose Cone Halves (type PNC-20ED) ..... 71006
- B 2 Tube Adapter Halves (type PTA-2050) ..... 30100
- C 1 Engine Mount Tube (type BT-20J) ..... 30326
- D 1 Engine Hook (type EH-2) .... 35025
- E 2 Adapter Rings (type AR-2050) .30164
- F 1 Shock Cord Mount (type SCM-50) ..... 84444
- G 1 Shock Cord (type SC-1) ..... 85730
- H 2 Fin Unit Halves (type PFU-54ED) ..... 32412
- I 1 Body Tube (type BT-50) ..... 30352
- J 1 Body Tube (type BT-20) ..... 30316
- K 1 Launch Lug (type LL-2A) .... 38175
- L 1 Parachute (type PK-12A) .... 85564
- M 1 Shroud Line (type SLT-72) .. 38237
- N 1 Tape Discs (type TD-3F) ..... 38406
- O 1 Decal (type KD-1344) ..... 37151

### TOOLS AND MATERIALS

In addition to the parts included in this kit you will need tube-type plastic cement, white glue (Titebond, Elmer's or similar household white glue is recommended.), scissors, pencil, rubber bands, modeling knife, copper enamel spray paint, gloss white enamel spray paint, and aircraft gray spray paint.

**RECOMMENDED ENGINES:**  
A8-3 B4-4 B6-4 B8-5 B14-5 C6-5 C6-7

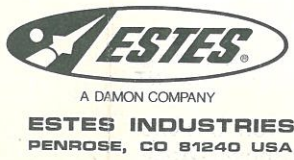

# ASSEMBLY INSTRUCTIONS

1

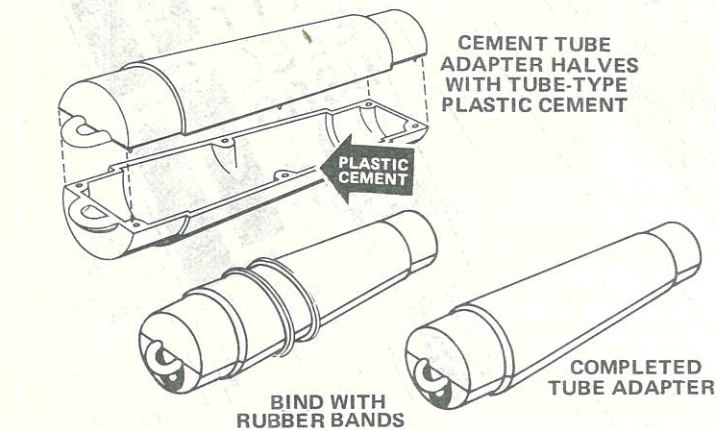
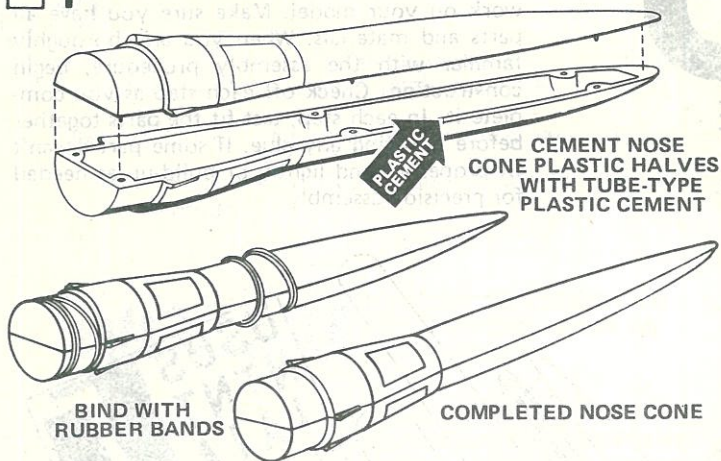

Cement nose cone plastic halves (part A) and tube adapter halves (part B) together with tube-type plastic cement. Wrap a rubber band around nose cone to hold halves tightly together until dry. Do the same with the tube adapter unit as shown.

2

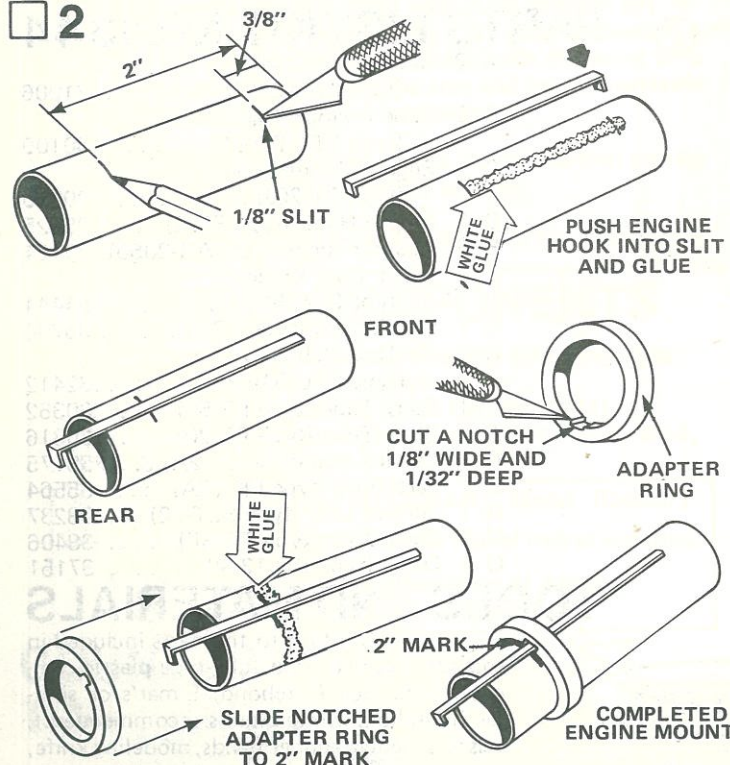

Mark the engine mount tube (part C) at 3/8" and 2" from one end. Cut a 1/8" long slit in the tube at the 3/8" mark as shown. Apply

a dab of glue to the slit and a line of glue between the slit and the 2" mark. Push one end of the engine hook (part D) into the slit. Press the main part of the hook into the glue. Be sure that the hook runs straight along the tube. Cut a notch 1/8" wide and 1/32" deep on the inside of one adapter ring (part E). Apply a line of glue around the engine mount tube just ahead of the 2" mark. Slide the notched ring onto the rear of the tube, over the engine hook, and ahead of the 2" mark. Be sure notch is centered over the hook and the hook runs straight along the tube.

3

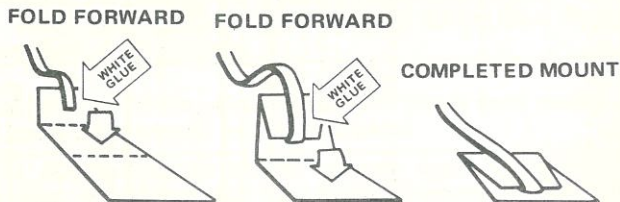

Cut out the shock cord mount (part F). Crease it on the dotted lines by folding. Spread glue on to the first section (1) and lay the end of the shock cord (part G) into the glue. Fold over and apply glue to the back of the first section and the exposed part of section (2). Lay the shock cord as shown and fold over again. Clamp the unit together with your fingers until the glue "sets".

4

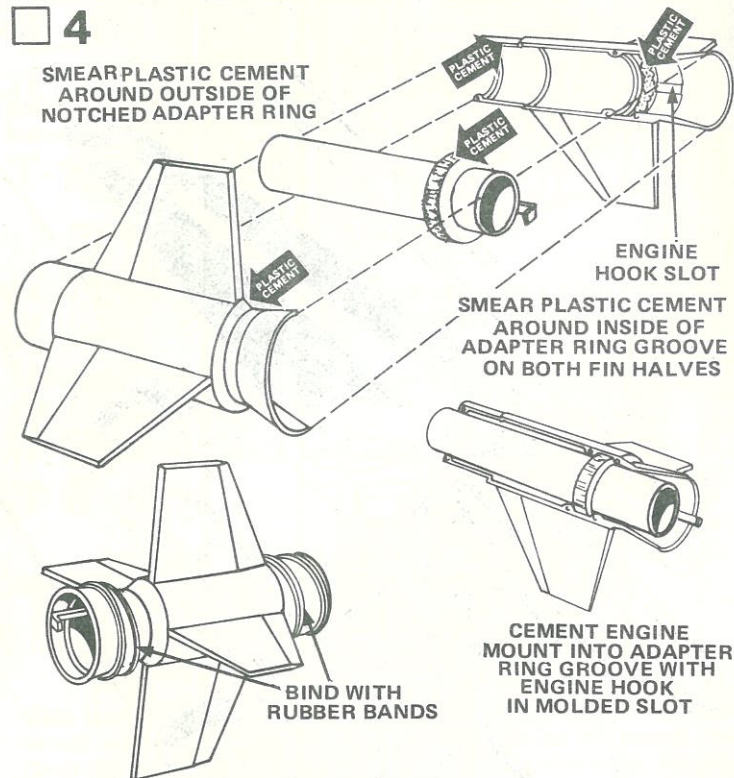

Smear a coat of tube-type plastic cement around the outside of the notched adapter ring on the engine mount and allow to dry. Apply a small amount of plastic cement in the adapter ring groove of one of the fin unit halves (part H). Lay the engine mount in place so that the engine hook fits in the molded slot. Apply tube-type plastic cement around inside adapter ring groove and along edges of other fin unit half and put the halves together. Bind with rubber bands until dry.

5

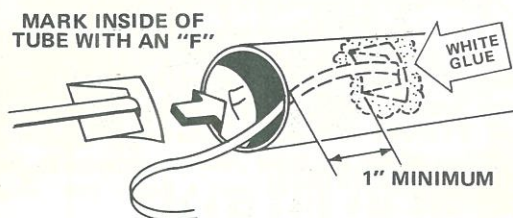

Apply glue to the inside of the large body tube (part I) at one end over an area about 1" to 2" from the end. The glued area should be the same size as the shock cord mount. Press the mount into the glue as shown and hold it until the glue sets. Mark an "F" (Front) on the inside of the tube as shown.

6

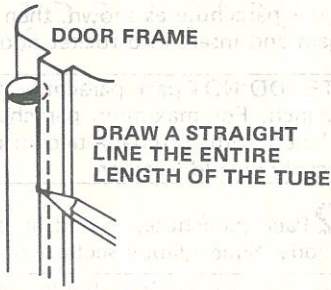

Draw a straight line along one side of the rocket body tube. Place the body tube against the inside edge of a door frame as shown. Draw the line the length of the tube.

7

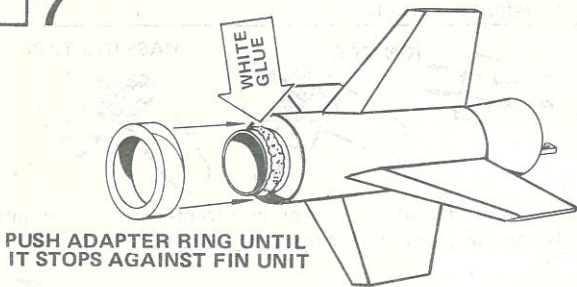

Apply glue to the front of the engine mount tube that extends out of the fin unit as shown. Push adapter ring on tube until it stops against fin unit.

8

SMEAR TUBE TYPE PLASTIC CEMENT AROUND INSIDE OF UPPER STAGE BODY TUBE

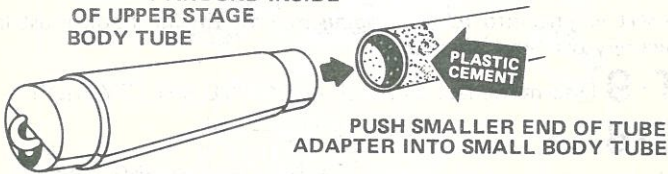

Smear plastic cement inside one end of the upper stage body tube (part J). Slide smaller end of tube adapter into body tube and allow to dry.

9

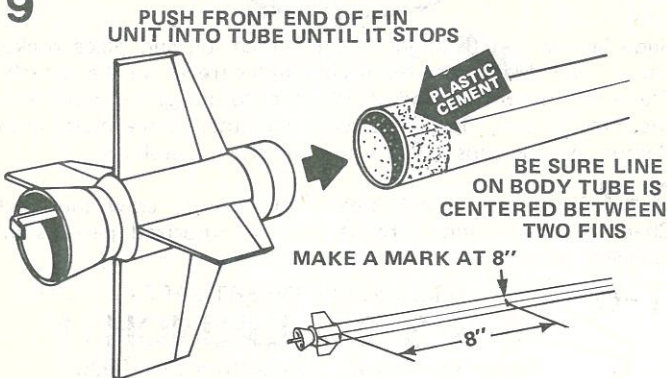

Apply plastic cement to the inside of the end of large rocket body tube (the end not marked with an "F"). Immediately push front portion of fin unit into tube until it stops against the body tube. Make sure the line drawn in Step 6 is centered between two fins of the fin unit. Make a mark on this line 8" forward of the fin unit/body tube joint.

10

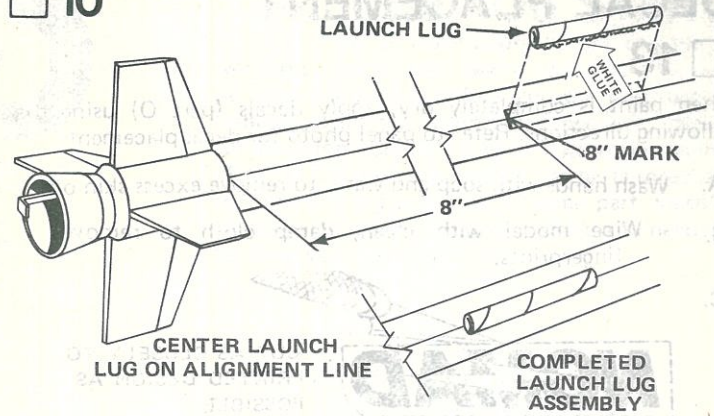

Apply a line of glue along one side of the launch lug (part K). Position the launch lug so the rear of the launch lug is on the 8" mark and the launch lug is centered on the alignment line.

11

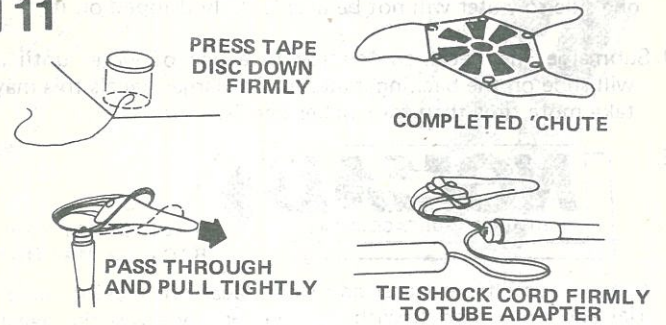

Cut out the parachute (part L) on its edge lines. Cut three 24" lengths of shroud line (part M). Attach line ends to the top (printed side) of the parachute with tape discs (part N) as shown. Pass the shroud line loop ends through the tube adapter eyelet. Pass the parachute through the loop ends and pull the lines tight against the eyelet. "Set" the knot with a drop of glue. Tie the free end of the shock cord to the eyelet with a double knot. Pack chute and shock cord into rocket body. Slide upper stage into place. Then slide nose cone into place on upper stage.

## PAINTING AND DETAILING

12

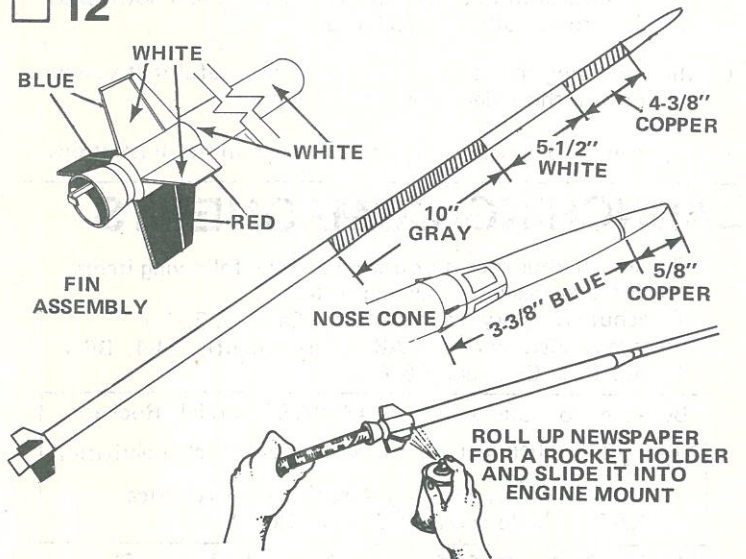

Roll up a piece of newspaper for a rocket holder and slide it into the engine mount as shown. Paint entire rocket body gloss white. Apply at least two coats of spray paint. Allow each coat to dry completely. Follow painting instructions on spray can for best results. After base paint is thoroughly dry, paint rocket as per illustration.

# DECAL PLACEMENT

## 13

When paint is completely dry, apply decals (part O) using the following directions. Refer to panel photo for decal placement.

- A. Wash hands with soap and water to remove excess skin oil.
- B. Wipe model with clean, damp cloth to remove fingerprints.
- C.



CUT AS CLOSELY TO PRINTED DESIGN AS POSSIBLE

Select the particular decal you wish to apply. Cut only that decal from the sheet, trimming as closely as possible to the printed design. Place the remainder of the decal sheet to one side so water will not be accidentally dripped on it.

- D. Submerge the decal completely in a pan of water until it will slide on the backing material. For larger decals this may take more time than for smaller decals.



SLIDE DECAL OFF BACKING MATERIAL

Remove decal from water and slide decal off backing material and onto model. With tweezers gently move the decal until it is in the desired position. If the decal "grabs" and will not move, do not force it. Use a paint brush to apply a little water to the decal surface. The water will run under the decal so you can move it easily.

- F. Let decal set a couple of minutes, then blot gently with a clean cloth to remove excess water and air bubbles. Do not rub the cloth back and forth or you may move or wrinkle the decal. After decal has set for another 3 or 4 minutes, you may gently rub the cloth over it to remove any remaining moisture or trapped air. If you encounter a stubborn air bubble, prick the bubble with the point of a pin, place a drop of water on the area and press down with the cloth to smooth the decal into place.

- G. When applying the rest of the decals, be careful that you do not disturb those decals previously applied.

- H. Apply all the decals in the locations shown in the illustrations.

# LAUNCHING COMPONENTS

To launch your rocket you will need the following items:

- An Estes model rocket launch system
- Parachute recovery wadding (Estes Cat. No. 2274)
- Recommended engines: A8-3 (first flight), B4-4, B6-4, B8-5, B14-5, C6-5, and C6-7

Be sure to follow the HIAA-NAR\* Model Rocketry Safety Code when carrying out your model rocket activities.

\*HIAA -- Hobby Industry Association of America  
NAR -- National Association of Rocketry

# COUNTDOWN CHECKLIST

## T-14

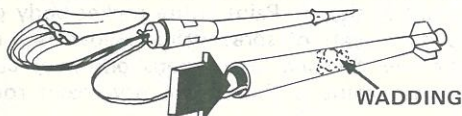

WADDING

Pack 4 or 5 squares of recovery wadding into the body tube.

## T-13

PULL TIGHTLY



FOLD

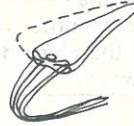

Gather the parachute as shown, then fold into a triangular shape. Fold again and insert into rocket body.

NOTE: DO NOT pack parachute until you are actually ready to launch. For maximum parachute reliability, lightly dust the 'chute with ordinary talcum powder before each flight, especially in cold weather.

## T-12

Pack parachute, shroud lines, and shock cord neatly into rocket body. Slide adapter section into place.

NOTE: Adapter section should separate easily from rocket body tube, but should not be extremely loose. If fit is too tight, sand inside of body tube and shoulder of adapter section with fine sandpaper. If fit is too loose, add a wrapping of transparent tape or masking tape to the shoulder of the nose cone and adapter section.

## T-11

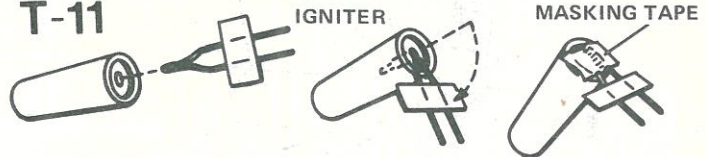

IGNITER

MASKING TAPE

Select an engine and install an igniter as directed in the engine instructions. Use an A8-3 engine for your first flight.

## T-10

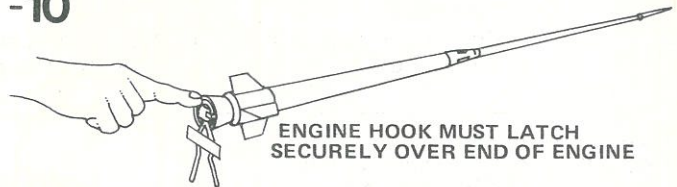

ENGINE HOOK MUST LATCH SECURELY OVER END OF ENGINE

Insert engine into rocket engine mount. Engine hook must latch securely over end of engine.

## T-9

Disarm the launch panel -- REMOVE SAFETY KEY!

## T-8

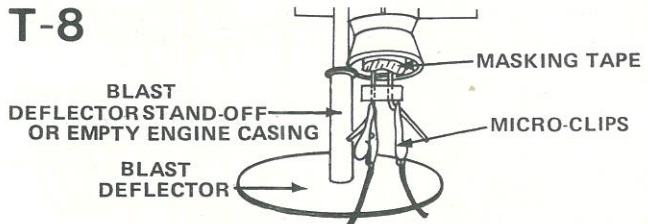

BLAST DEFLECTOR STAND-OFF OR EMPTY ENGINE CASING

BLAST DEFLECTOR

MASKING TAPE

MICRO-CLIPS

Slide launch rod through rocket launch lug and place rocket on launch pad. Make sure the rocket slides freely on the launch rod. Clean the micro-clips and attach them to the igniter wires. Arrange the clips so they do not touch each other or the metal blast deflector. Attach clips as close to engine as possible.

## T-7

Clear the launch area, alert recovery crew and trackers. Check for low flying aircraft and unauthorized persons in the recovery area.

## T-6

Arm the launch panel -- INSERT SAFETY KEY!

**-5-4-3-2-1-LAUNCH!!**

Repeat Countdown Checklist for each flight.

# MISFIRE PROCEDURE

Occasionally the igniter will heat and burn into two pieces without igniting the engine. This is almost always caused by a failure to install it correctly. REMOVE SAFETY KEY from launch panel, remove the model, clean the igniter residue from the engine nozzle, and install a new igniter. Repeat the Countdown Checklist.