

WORLD FEDERATION STAR PROBE

SKILL LEVEL 3 — Recommended for Craftsman Rocketeers.

RECOMMENDED ENGINES:

A8-3 B4-2 B4-4 B6-2 B6-4

B8-5 B14-5 C6-5 C6-7

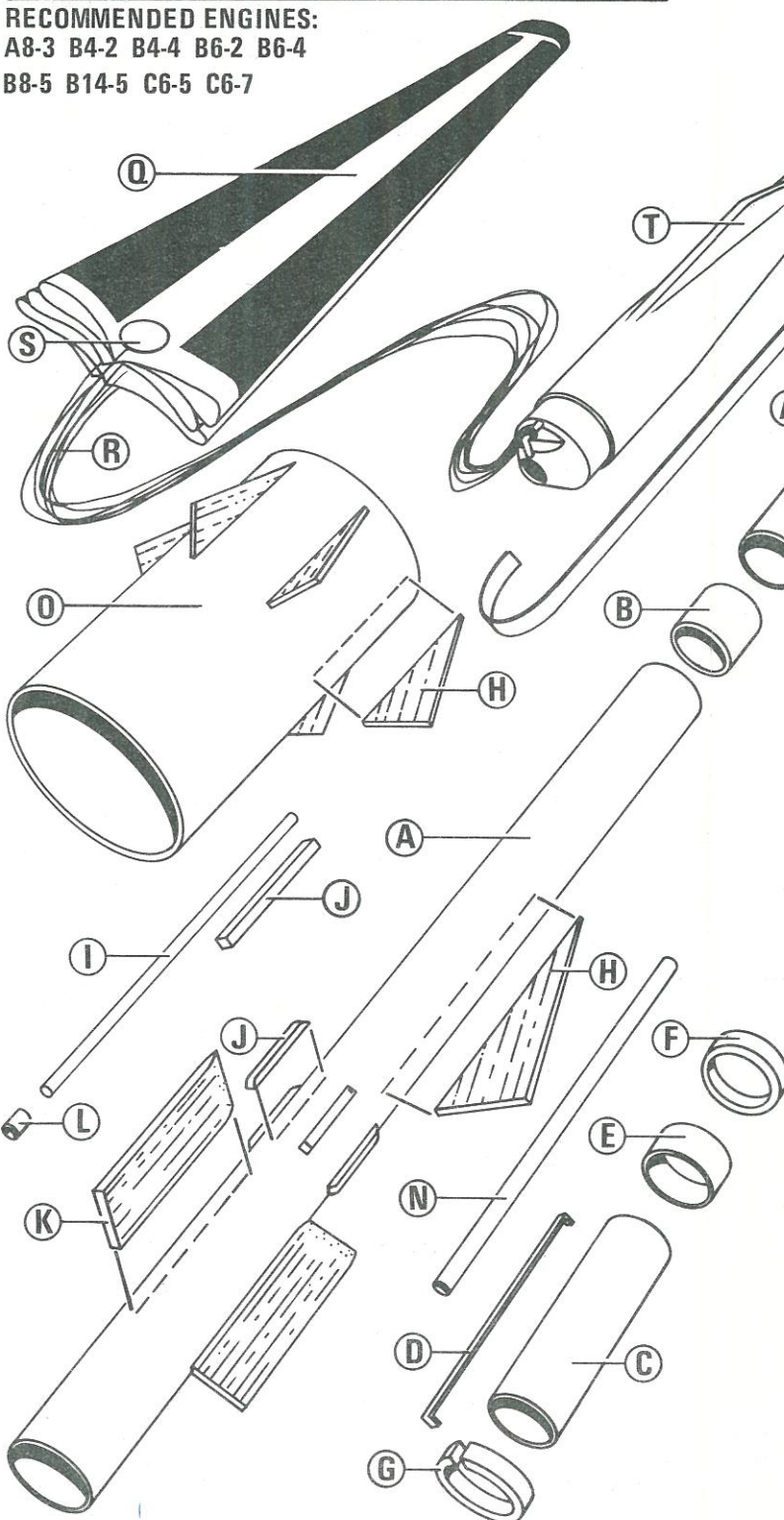

BEFORE YOU START

Read all instructions before beginning work on your model. Make sure you have all parts and materials. When you are thoroughly familiar with the assembly procedure, begin construction. Check off each step as you complete it. In each step, test-fit the parts together before applying any glue. If some part doesn't fit properly sand lightly or build up as required for precision assembly.



KIT NO. 1341 PARTS LIST

A	2	Body Tubes (type BT-50L)	30366
B	1	Body Tube Coupler (type JT-50C)	30260
C	1	Engine Mount Tube (type BT-20J)	30326
D	1	Engine Hook (type EH-2)	35025
E	1	Hook Retainer Ring (type HR-20)	30168
F	1	Centering Ring (type AR-2050)	30164
G	1	Split Centering Ring (type AR-2050S)	80425
H	1	Die-Cut Balsa Sheet (type BF-1341)	32345
I	1	1/8" Wood Dowel	85903
J	1	1/8" Square Wood Strip	85926
K	1	Balsa Strip	32279
L	1	Launch Lug (type LL-2AM)	38176
M	1	Pattern Sheet (type SP-1341)	84208
N	1	Launch Lug (type LL-2C)	38180
O	1	Stabilizer Ring (type BT-80S)	30427
P	1	Shock Cord (type SC-1)	85730
Q	1	Parachute (type PK-12)	85564
R	1	Shroud Line (type SLT-72)	38237
S	1	Tape Discs (type TD-3F)	38406
T	1	Nose Cone (type PNC-50SP)	71001
U	1	Decal (type KD-1341B)	37572
V	1	Mylar Stick-On Decal (type KD-1341A)	37705

TOOLS AND MATERIALS

In addition to the parts included in this kit you will need white glue (Titebond, Elmer's, or similar household white glue is recommended.), scissors, pencil, ruler, fine and extra-fine grit sandpaper, sanding sealer, masking tape, a medium size modeling paint brush, modeling knife with sharp blade, tweezers, white enamel spray paint, and a bottle of black enamel paint.

ASSEMBLY INSTRUCTIONS

1

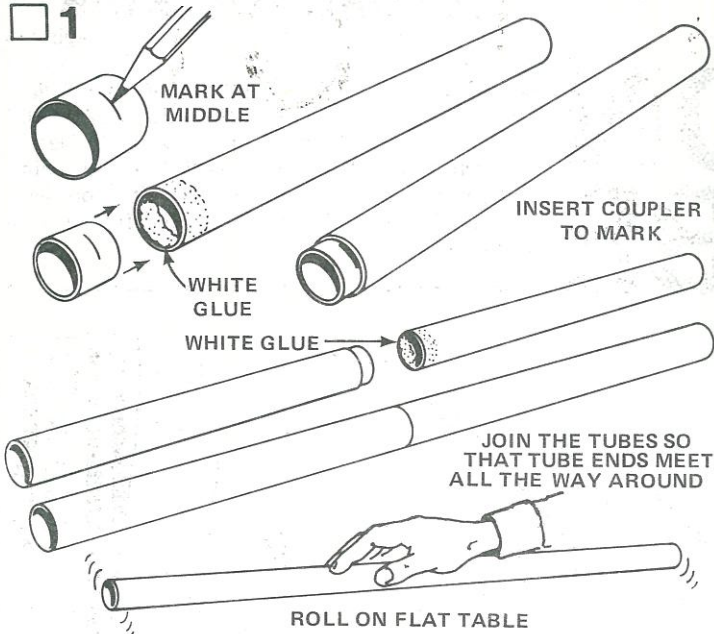

Assemble the main body. Mark the body tube coupler (part B) at its middle. Smear glue around the inside of one end of one body tube (part A). Insert coupler into the glued end so half of the coupler is in the tube. Let glue set, then smear glue inside one end of the other body tube and slide glued end onto the coupler to join the tubes. Lay assembly on a flat table top and roll gently to make sure the tubes are straight.

2

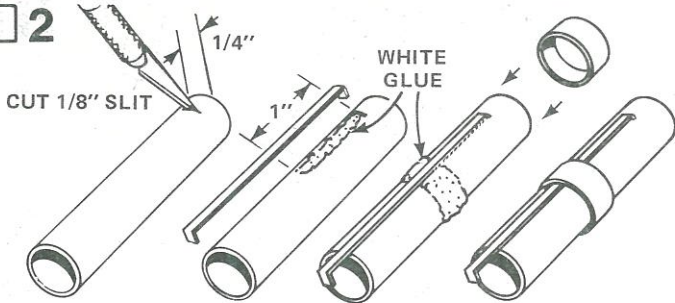

Cut a 1/8" long slit in the engine mount tube (part C), 1/4" from one end as shown. Apply a 1" long line of glue to the tube as shown. Push one end of the engine hook (part D) into the slit and press the main part of the hook into the glue. Apply a line of glue around the middle of the tube and slide the hook retainer ring (part E) over tube and hook and onto the glue.

3

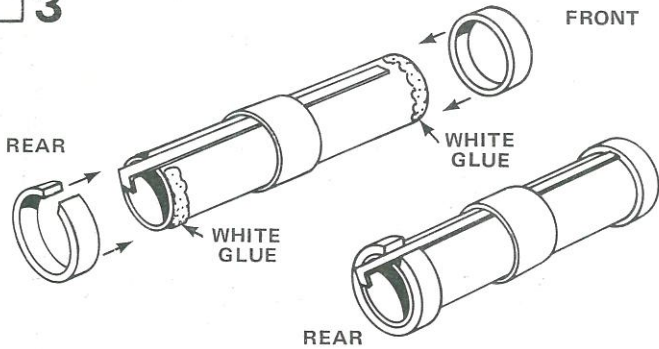

Glue the split centering ring (part G) to the engine mount tube even with the rear end (the end with the over-hanging hook) so the slot is over the hook. Avoid getting glue in the slot. Glue the other ring (part F) to the front of the engine mount against the end of the hook as shown.

4

FINE-SAND

CUT FINS FREE

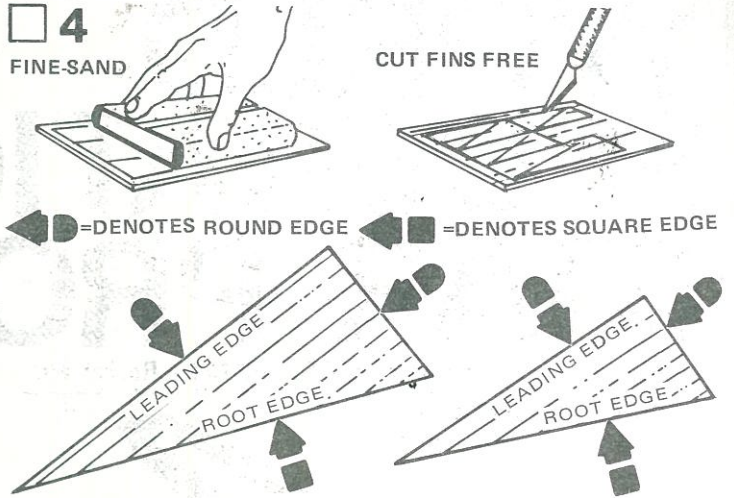

Fine-sand the balsa die-cut sheet (part H), then carefully remove the die-cut fins from the sheet. Free the edges with a sharp knife. Sand the leading and trailing edges of the fins round. Leave the other edges square.

5

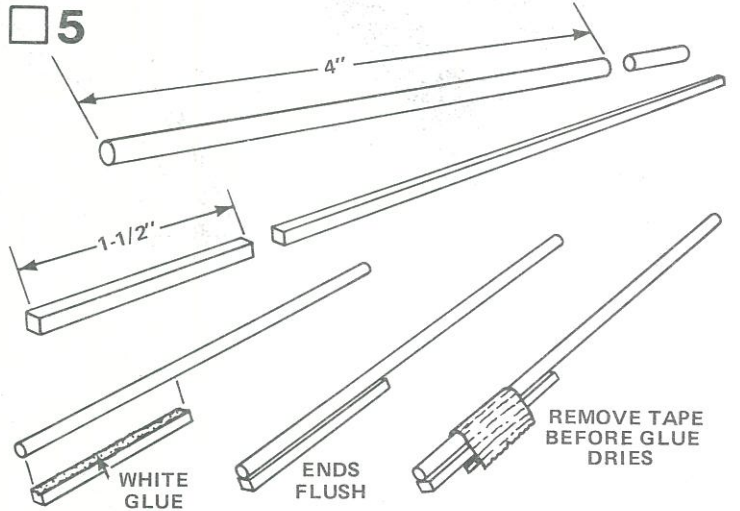

Locate the wood dowel (part I) and cut to 4" length. Next locate 1/8" square wood strip (part J) and cut it to 1-1/2" length. Set aside excess strip to be used in a following step. Apply glue down one side of 1-1/2" wood strip and position 4" dowel onto glue so end of dowel is flush with end of wood strip. Temporarily tape dowel into position. Remove tape as soon as glue sets. Do not wait until glue dries.

6

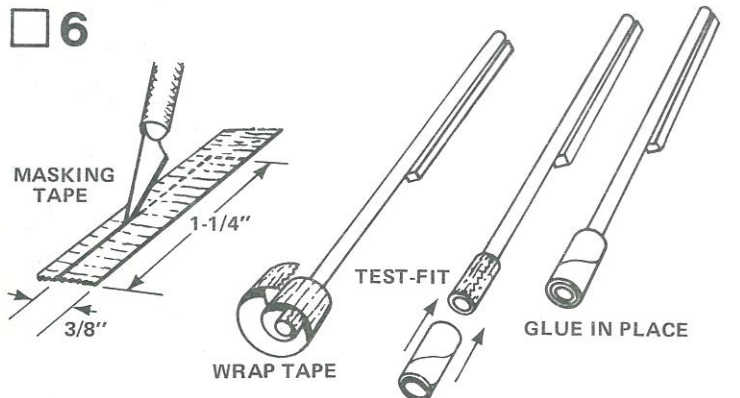

Cut a strip of masking tape 3/8" wide and 1-1/4" long. Wrap tape around the end of the dowel. Test-fit the small launch lug (part L) over tape. If too tight, remove tape 1/16" at a time until the lug fits smoothly on the dowel. Smear glue over tape and slide the lug into place on the dowel.

7

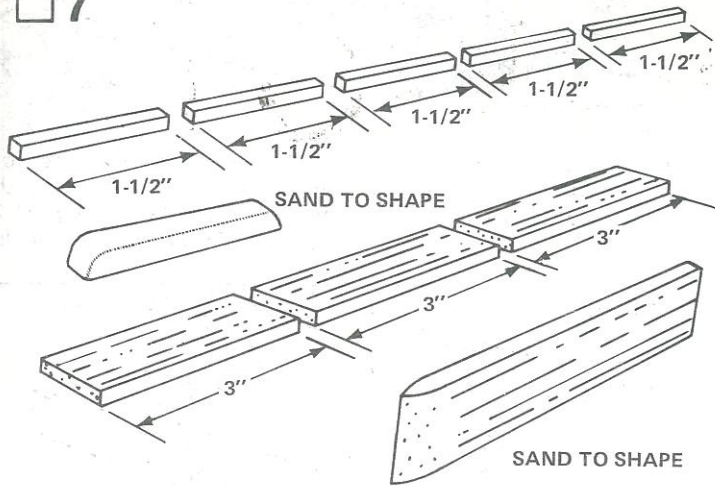

Cut remaining 1/8" square wood strip into five 1-1/2" lengths and sand ends to shape shown. Locate large balsa strip (part K) and cut into three 3" pieces. Sand front end of each piece as shown.

8

APPLY SEALER

SAND LIGHTLY WHEN DRY

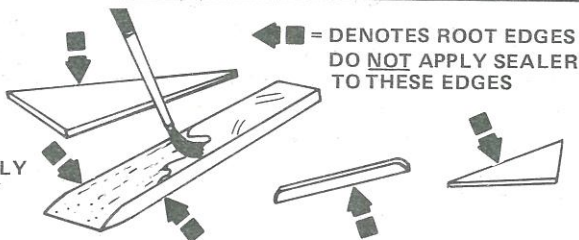

Apply a coat of sanding sealer to one side of all the wood parts, fins, and wood strips. When dry, turn parts over and apply sealer to other side. Apply sealer to all edges except root edge (the edge that glues to the body tube). When sealer is dry, lightly sand all surfaces. Repeat sealing and sanding process a second time. If balsa grain still shows, a third coat of sealer (and sanding) may be necessary.

9

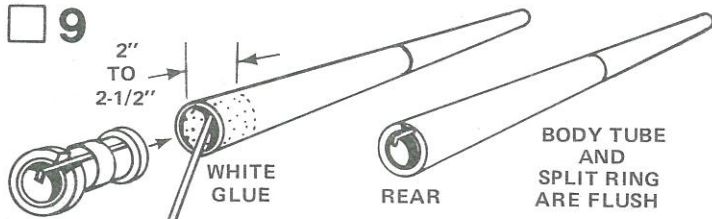

Smear glue around the inside of one end of the assembled body tubes to cover an area about 2" to 2-1/2" from the end of the tube. Use a stick or dowel as shown. Immediately insert the engine mount unit, being careful to position it so the engine hook will stick out of the end of the tube. Push engine mount in with one smooth motion until the ends of the tubes (and split ring) are even.

10

ALIGN LAUNCH LUG MARKS AND ENGINE HOOK

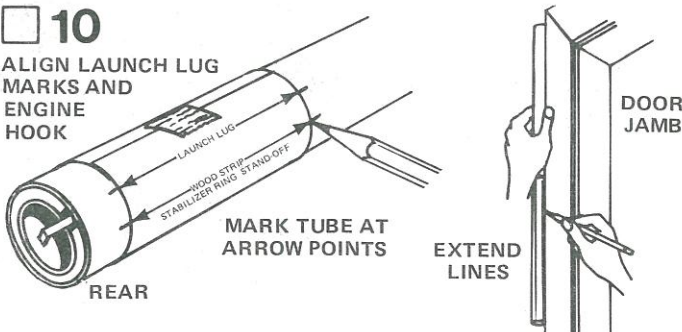

Cut out the body tube marking guide from the pattern sheet (part M). Wrap it around the rear of the body so the arrows labeled launch lug are in line with the engine hook. Mark the tube at each arrow point, front and rear. Draw a straight line connecting each matching front and rear marks by placing the body tube against the inside edge of a door frame as shown. Draw lines only up to the tube joint.

11

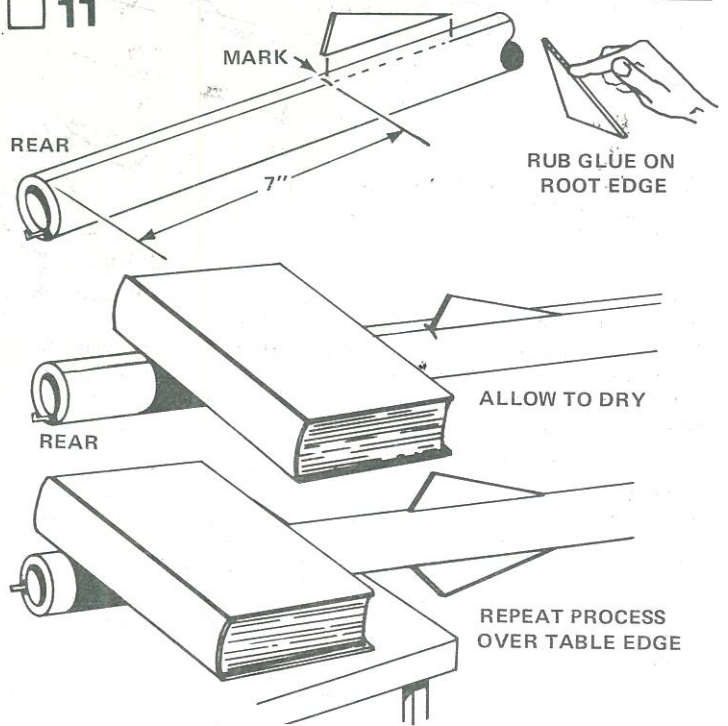

Measuring from the rear of the tube, place a mark at 7" on the two alignment lines labeled "forward fin". Rub a line of glue into the root edge of each forward fin and allow to dry, then apply another line of glue to the fin. Position the fin on the body tube on the fin alignment line so the rear of the fin is on the 7" mark and projects straight away from the tube. With the fin in an upright position, weight the body tube with a small book to hold tube in place. Allow glue to dry. Repeat same procedure for other fin.

12

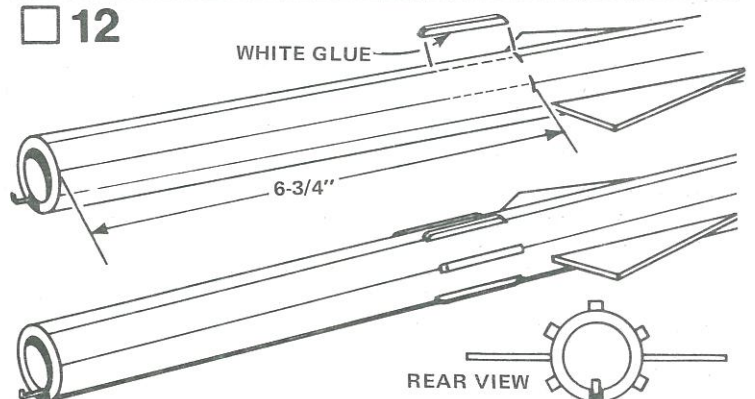

Measure 6-3/4" from the rear of the body tube and make a mark on each of the five 1/8" "wood strip alignment lines". Rub glue into each of the five 1-1/2" long wood strips and allow to dry. Then apply another line of glue to the wood strips and center each strip on one of the five center lines with its front on the 6-3/4" mark. Make sure each strip is centered on an alignment line.

13

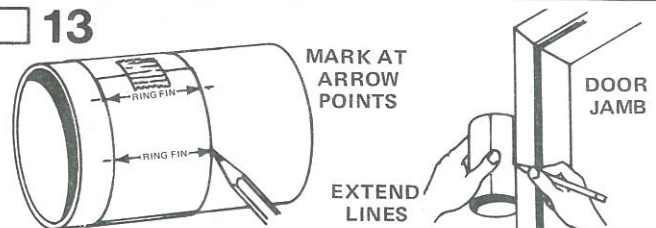

Cut out the stabilizer ring marking guide from the pattern sheet. Wrap it around the stabilizer ring (part O). Mark the ring at each arrow point, front and rear. Place the ring against the inside of a door frame as shown, and draw a straight line the length of the ring connecting each matching front and rear mark.

14

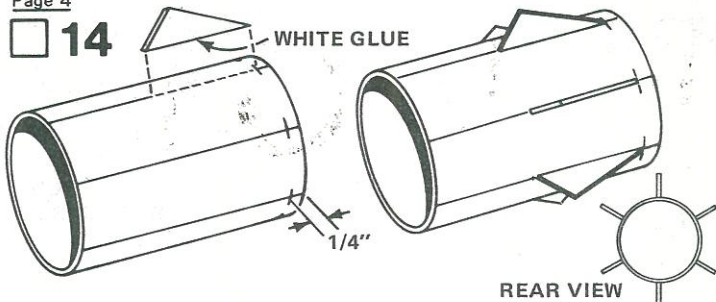

Place a mark 1/4" from one end of the ring at each of the six alignment lines drawn in Step 13 as shown. Find the six small triangular fins, rub glue into each root edge, and allow to dry. Then apply another line of glue on the root edge and center each fin on one of the alignment lines with the front tip of the fin at the 1/4" mark. Make sure each fin projects straight away from the stabilizer ring as shown. Set ring aside to dry.

15

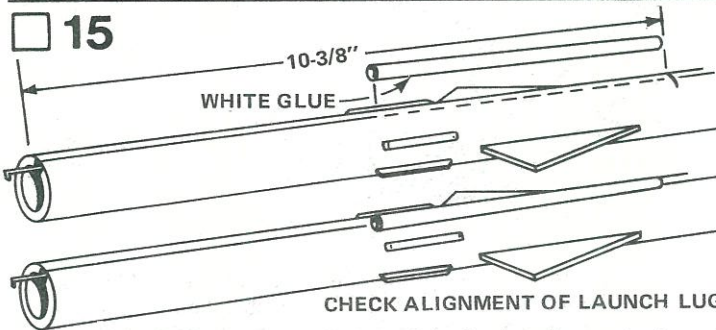

Place a mark 10-3/8" from the rear of the body tube on the launch lug alignment line. Smear glue along one edge of the launch lug (part N). Center launch lug on its alignment line with the front of the lug on the 10-3/8" mark. Make sure launch lug is straight and parallel with the edge of the body tube.

16

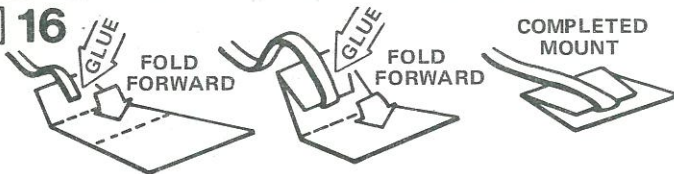

Cut out the shock cord mount from the pattern sheet. Pre-fold it on the dotted lines. Apply glue to section 1 and lay the shock cord (part P) into the glue. Fold over and apply glue to the back of the first section and the exposed part of section 2. Lay the shock cord as shown and fold over again. Clamp the unit together with your fingers until the glue sets.

17

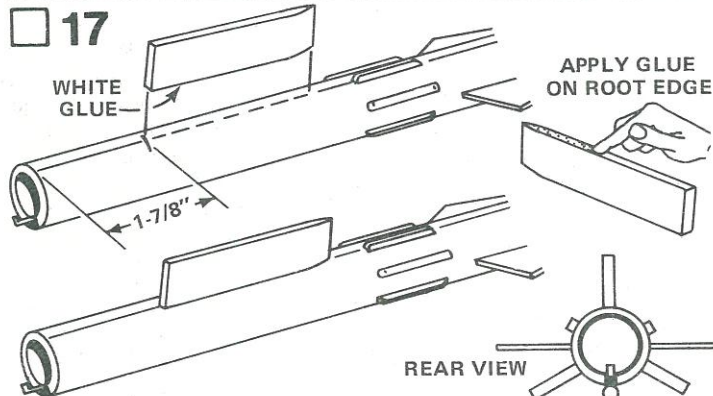

Locate the three stabilizer ring stand-offs from Step 7. Apply glue to root edges of each stand-off and allow to dry. Place a mark on each of the wood strip/stabilizer ring stand-off alignment lines 1-7/8" from the rear of the body tube. Apply another bead of glue to the stand-offs and center each one on its alignment line with the square rear of the stand-off on the 1-7/8" mark as shown. Make sure the stand-offs are centered on the body tube and project straight away from the tube.

18

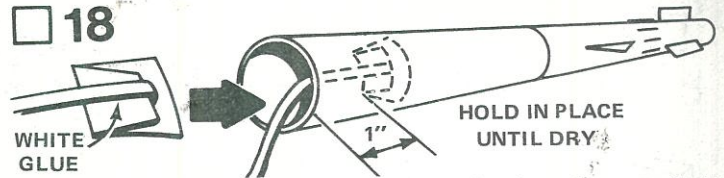

Smear glue over the entire back side of the shock cord mount. Hold the mount as shown and press it into place inside front end of the rocket body tube. Make sure the front of the mount is at least 1" from the end of the tube. Hold the mount in place until the glue "sets".

19

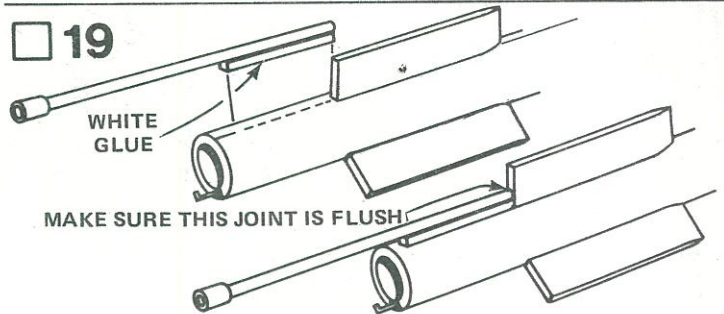

Apply glue to the wooden strip/dowel unit from Step 5 as shown. Glue this strip/dowel to the wood strip/stabilizer ring stand-off alignment line across from engine hook as shown. Make sure strip/dowel is positioned against the stabilizer ring stand-off and centered on the alignment line.

20

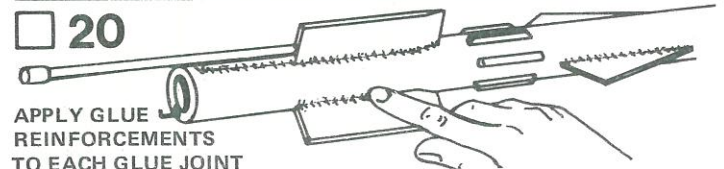

When all glue joints have dried, apply glue reinforcements to each glue joint. Hold model level and apply a line of glue to both sides of each joint. Smooth out the glue with your finger. Keep the model level until the glue dries.

21

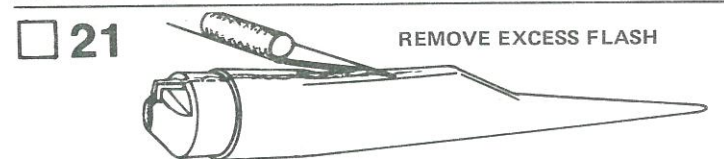

The plastic nose cone (part T) may have excess plastic ("flash") around the part line of the nose cone where the mold halves meet. Remove this flash from the nose cone with a modeling knife. Test-fit the nose cone in the body tube, if nose cone fits too tight, scrape nose cone shoulder section, at the part line for a better fit. Open the eyelet with extreme care.

22

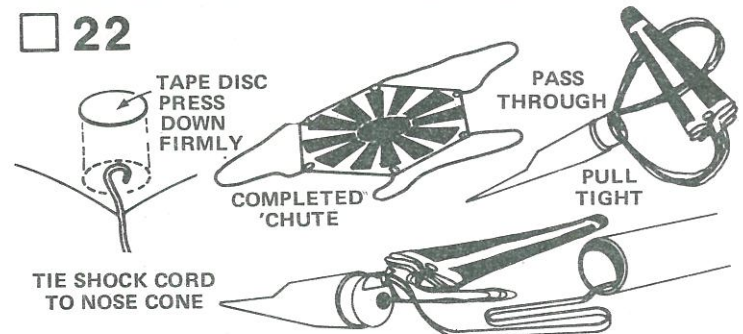

Cut out the parachute (part Q) on its edge lines. Cut three 24" lengths of shroud line (part R). Attach line ends to the top (printed side) of the parachute with tape discs (part S) as shown. Pass the shroud line loops through the nose cone (part T) eyelet. Pass the parachute through the loop ends and pull the lines tight against the eyelet. Tie the free end of the shock cord to the eyelet with a double knot. Pack chute and shock cord into rocket body. Slide nose cone into place.